

# VRF

## Technical Data Book

IDU 360 Cassette for EU (R410A/50Hz/HP/HR)



Model : AM\*\*\*KN4DEH/EU



# 1 Specifications

## 360 Cassette

Type			360 Cassette	360 Cassette	360 Cassette	360 Cassette	
Model			AM045KN4DEH/EU	AM056KN4DEH/EU	AM071KN4DEH/EU	AM090KN4DEH/EU	
Power Supply			Ø, #, V, Hz	1,2,220-240,50	1,2,220-240,50	1,2,220-240,50	
Mode			-	HP/HR	HP/HR	HP/HR	
Performance	Capacity (Nominal)	Cooling	kW	4.50	5.60	7.10	9.00
			Btu/h	15,400	19,100	24,200	30,700
		Heating	kW	5.00	6.30	8.00	10.00
			Btu/h	17,100	21,500	27,300	34,100
Power	Power Input (Nominal)	Cooling	W	26.00	30.00	34.00	55.00
		Heating	W	26.00	30.00	34.00	55.00
	Current Input (Nominal)	Cooling	A	0.18	0.21	0.25	0.42
		Heating	A	0.18	0.21	0.25	0.42
Fan	Motor	Type	-	Turbo Fan	Turbo Fan	Turbo Fan	Turbo Fan
		Output x n	w	65 x 1	65 x 1	65 x 1	65 x 1
	Air Flow Rate	H/M/L (UL)	CMM	14.50 / 13.50 / 12.50	16.00 / 14.50 / 13.50	18.00 / 16.00 / 14.00	22.00 / 18.50 / 16.00
			l/s	241.67 / 225.00 / 208.33	266.67 / 241.67 / 225.00	300.00 / 266.67 / 233.33	366.67 / 308.33 / 266.67
External Pressure	Min/Std/Max	mmAq	-	-	-	-	
		Pa	-	-	-	-	
Piping Connections	Liquid Pipe	Ø, mm	6.35	6.35	9.52	9.52	
		Ø, inch	1/4"	1/4"	3/8"	3/8"	
	Gas Pipe	Ø, mm	12.70	12.70	15.88	15.88	
		Ø, inch	1/2"	1/2"	5/8"	5/8"	
Drain Pipe	Ø, mm	VP25 (OD 32,ID 25)	VP25 (OD 32,ID 25)	VP25 (OD 32,ID 25)	VP25 (OD 32,ID 25)		
Field Wiring	Power Source Wire	mm <sup>2</sup>	1.5 - 2.5	1.5 - 2.5	1.5 - 2.5	1.5 - 2.5	
	Transmission Cable	mm <sup>2</sup>	0.75 - 1.50	0.75 - 1.50	0.75 - 1.50	0.75 - 1.50	
Refrigerant	Type	-	R410A	R410A	R410A	R410A	
	Control Method	-	EEV INCLUDED	EEV INCLUDED	EEV INCLUDED	EEV INCLUDED	
Sound	Pressure	High / Mid / Low	dB(A)	33 / 31 / 29	34 / 32 / 29	36 / 33 / 30	40 / 36 / 32
	Power	Cooling		50	51	53	57
Dimension	Net Weight		kg	21.00	21.00	21.00	21.00
	Shipping Weight		kg	25.00	25.00	25.00	25.00
	Net Dimensions (WxHxD)		mm	947 x 281 x 947	947 x 281 x 947	947 x 281 x 947	947 x 281 x 947
	Shipping Dimensions (WxHxD)		mm	990 x 330 x 990	990 x 330 x 990	990 x 330 x 990	990 x 330 x 990
Panel Size	Panel model		-	PC4NUDMAN	PC4NUDMAN	PC4NUDMAN	PC4NUDMAN
	Panel Net Weight		kg	3.60	3.60	3.60	3.60
	Shipping Weight		kg	6.00	6.00	6.00	6.00
	Net Dimensions (WxHxD)		mm	1,000 x 66 x 1,000	1,000 x 66 x 1,000	1,000 x 66 x 1,000	1,000 x 66 x 1,000
	Shipping Dimensions (WxHxD)		mm	1,093 x 85 x 1,083	1,093 x 85 x 1,083	1,093 x 85 x 1,083	1,093 x 85 x 1,083
Additional Accessories	Drain Pump	Drain Pump	- / Model	-	-	-	-
		Max. lifting Height / Displacement	mm/liter/h	-	-	-	-
	Air Filter		-	-	-	-	-

\* Specifications may be subject to change without prior notice.

1) Nominal cooling capacities are based on;

- Indoor temperature : 27°C DB, 19°C WB

- Outdoor temperature : 35°C DB, 24°C WB, Equivalent refrigerant piping : 5m, Level differences : 0m

2) Nominal heating capacities are based on;

- Indoor temperature : 20°C DB, 15°C WB

- Outdoor temperature : 7°C DB, 6°C WB, Equivalent refrigerant piping : 5m, Level differences : 0m

3) Sound pressure was acquired in an anechoic room. Thus actual noise level may be different depending on the installation conditions.

4) These products contain R410A which is fluorinated greenhouse gas.

5) Panel type is option. (Ceiling Type/Open Type)

About each detail spec, please refer to Dimensional Drawing pages.

# 1 Specifications

## 360 Cassette

Type			360 Cassette		360 Cassette		360 Cassette	
Model			AM112KN4DEH/EU		AM128KN4DEH/EU		AM140KN4DEH/EU	
Power Supply			Ø, #, V, Hz	1,2,220-240,50	1,2,220-240,50	1,2,220-240,50	1,2,220-240,50	
Mode			-	HP/HR	HP/HR	HP/HR	HP/HR	
Performance	Capacity (Nominal)	Cooling	kW	11.20	12.80	14.00		
			Btu/h	38,200	43,700	47,800		
		Heating	kW	12.50	13.80	16.00		
			Btu/h	42,700	47,100	54,600		
Power	Power Input (Nominal)	Cooling	W	53.00	77.00	91.00		
		Heating	W	53.00	77.00	91.00		
	Current Input (Nominal)	Cooling	A	0.41	0.62	0.75		
		Heating	A	0.41	0.62	0.75		
Fan	Motor	Type	-	Turbo Fan	Turbo Fan	Turbo Fan		
		Output x n	w	97 x 1	97 x 1	97 x 1		
	Air Flow Rate	H/M/L (UL)	CMM	25.50 / 21.00 / 17.50	29.50 / 24.00 / 19.00	31.50 / 26.50 / 21.00		
			l/s	425.00 / 350.00 / 291.67	491.67 / 400.00 / 316.67	525.00 / 441.67 / 350.00		
	External Pressure	Min/Std/Max	mmAq	-	-	-		
Pa			-	-	-			
Piping Connections	Liquid Pipe		Ø, mm	9.52	9.52	9.52		
			Ø, inch	3/8"	3/8"	3/8"		
	Gas Pipe		Ø, mm	15.88	15.88	15.88		
			Ø, inch	5/8"	5/8"	5/8"		
Drain Pipe		Ø, mm	VP25 (OD 32,ID 25)	VP25 (OD 32,ID 25)	VP25 (OD 32,ID 25)			
Field Wiring	Power Source Wire		mm <sup>2</sup>	1.5 - 2.5	1.5 - 2.5	1.5 - 2.5		
	Transmission Cable		mm <sup>2</sup>	0.75 - 1.50	0.75 - 1.50	0.75 - 1.50		
Refrigerant	Type		-	R410A	R410A	R410A		
	Control Method		-	EEV INCLUDED	EEV INCLUDED	EEV INCLUDED		
Sound	Pressure	High / Mid / Low	dB(A)	40 / 36 / 32	42 / 38 / 33	44 / 40 / 35		
	Power	Cooling		58	60	61		
Dimension	Net Weight		kg	24.00	24.00	24.00		
	Shipping Weight		kg	29.00	29.00	29.00		
	Net Dimensions (WxHxD)		mm	947 x 365 x 947	947 x 365 x 947	947 x 365 x 947		
	Shipping Dimensions (WxHxD)		mm	990 x 414 x 990	990 x 414 x 990	990 x 414 x 990		
Panel Size	Panel model		-	PC4NUDMAN	PC4NUDMAN	PC4NUDMAN		
	Panel Net Weight		kg	3.60	3.60	3.60		
	Shipping Weight		kg	6.00	6.00	6.00		
	Net Dimensions (WxHxD)		mm	1,000 x 66 x 1,000	1,000 x 66 x 1,000	1,000 x 66 x 1,000		
	Shipping Dimensions (WxHxD)		mm	1,093 x 85 x 1,083	1,093 x 85 x 1,083	1,093 x 85 x 1,083		
Additional Accessories	Drain Pump	Drain Pump	- / Model	-	-	-		
		Max. lifting Height / Displacement	mm/liter/h	-	-	-		
	Air Filter			-	-	-		

\* Specifications may be subject to change without prior notice.

1) Nominal cooling capacities are based on;

- Indoor temperature : 27°C DB, 19°C WB

- Outdoor temperature : 35°C DB, 24°C WB, Equivalent refrigerant piping : 5m, Level differences : 0m

2) Nominal heating capacities are based on;

- Indoor temperature : 20°C DB, 15°C WB

- Outdoor temperature : 7°C DB, 6°C WB, Equivalent refrigerant piping : 5m, Level differences : 0m

3) Sound pressure was acquired in an anechoic room. Thus actual noise level may be different depending on the installation conditions.

4) These products contain R410A which is fluorinated greenhouse gas.

5) Panel type is option. (Ceiling Type/Open Type)

About each detail spec, please refer to Dimensional Drawing pages.

# 3 Dimensional drawing

## 360 Cassette

AM045KN4DEH/EU, AM056KN4DEH/EU, AM071KN4DEH/EU, AM090KN4DEH/EU

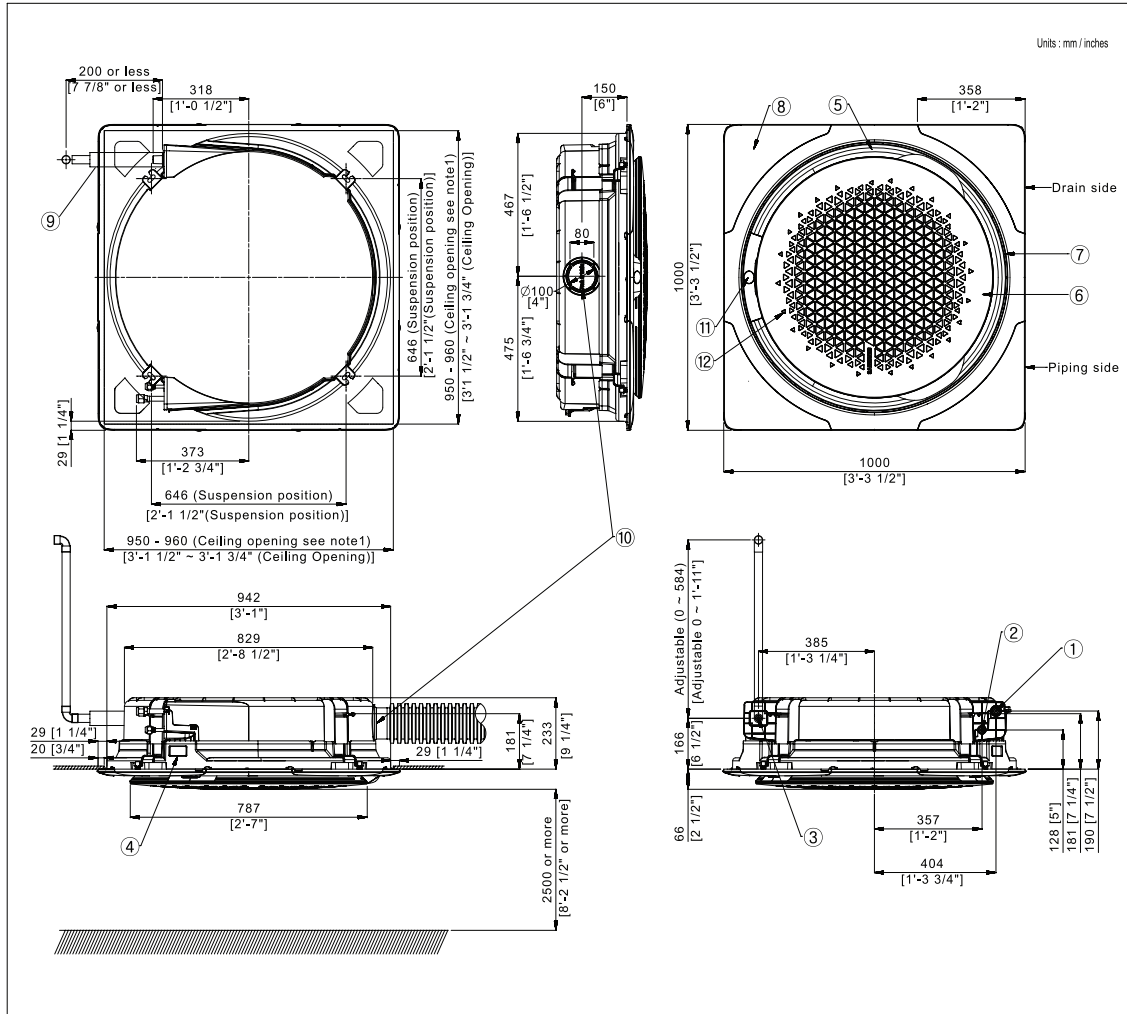

### Note

1. Make sure the spacing between the ceiling and the cassette is no more than 10mm[3/8"].
2. When the conditions exceed 30°C[86°F] and RH 80% in the ceiling or fresh air is inducted into the ceiling, and additional insulation is required (polyethylene foam, thickness 10mm[3/8"] or more)
3. Ceiling type panel model code : PC4NUDMAN

Table of descriptions

1	Refrigerant gas pipe	7	Suction rim for Booster fan
2	Refrigerant liquid pipe	8	Decoration cover
3	Condensate drain	9	Drain hose
4	Power & Comm. wiring conduits	10	Fresh air intake knock out hole
5	Air discharge opening	11	Display window
6	Air suction grille	12	Infrared receiver

# 3 Dimensional drawing

## 360 Cassette

AM112KN4DEH/EU, AM128KN4DEH/EU, AM140KN4DEH/EU

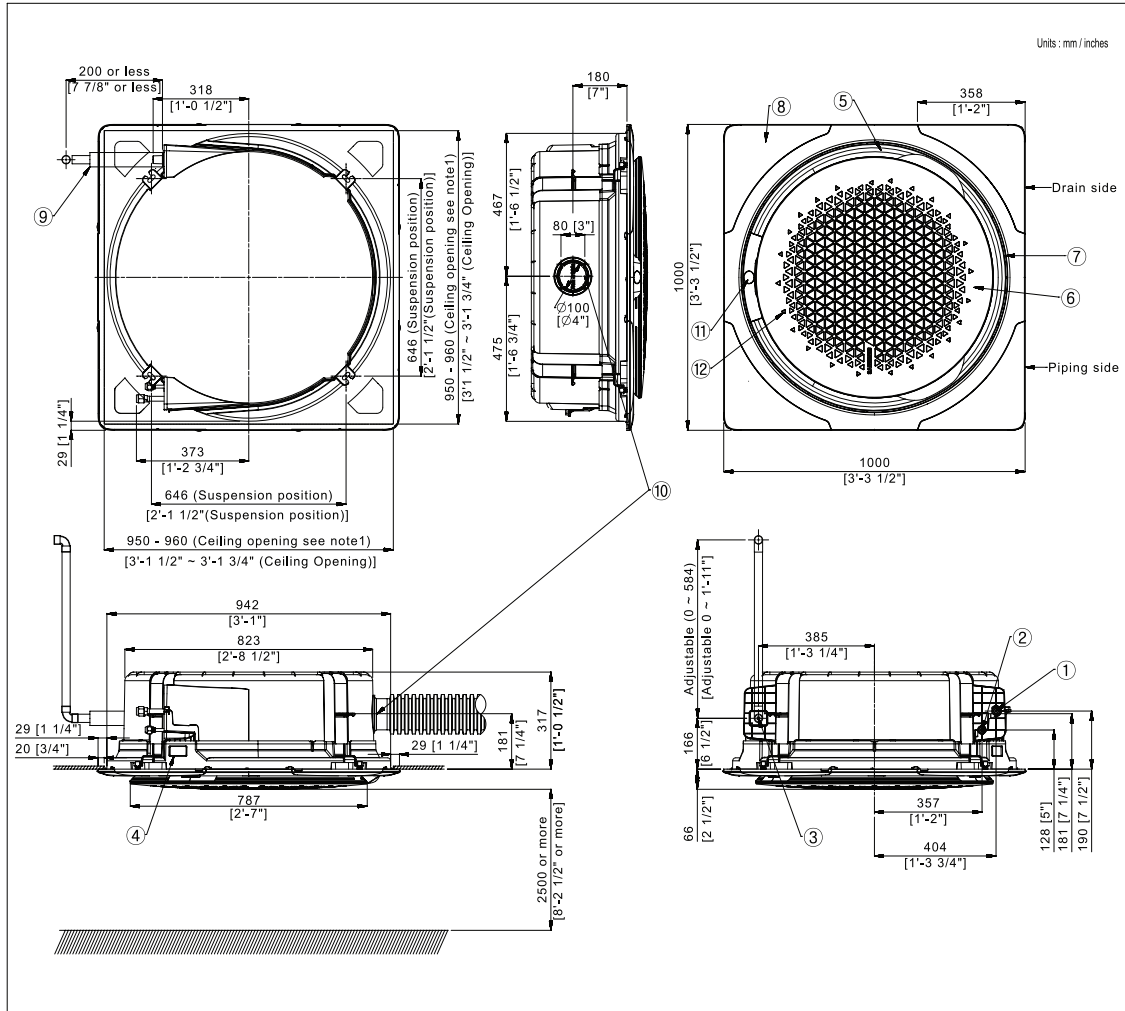

### Note

1. Make sure the spacing between the ceiling and the cassette is no more than 29mm[1 1/4"]. Max ceiling opening : 960mm[3'-1 3/4"]
2. When the conditions exceed 30 °C and RH 80% in the ceiling or fresh air is induced into the ceiling, and additional insulation is required (polyethylene foam, thickness 10mm[3/8"] or more)
3. Ceiling type panel model code : PC4NUDMAN

Table of descriptions

1	Refrigerant gas pipe	7	Suction rim for Booster fan
2	Refrigerant liquid pipe	8	Corner decoration cover
3	Condensate drain	9	Drain hose
4	Power & Comm. wiring conduits	10	Fresh air intake knock out hole
5	Air discharge opening	11	Display window
6	Air suction grille	12	Infrared receiver

# 3 Dimensional drawing

## 360 Cassette

AM045KN4DEH/EU, AM056KN4DEH/EU, AM071KN4DEH/EU, AM090KN4DEH/EU

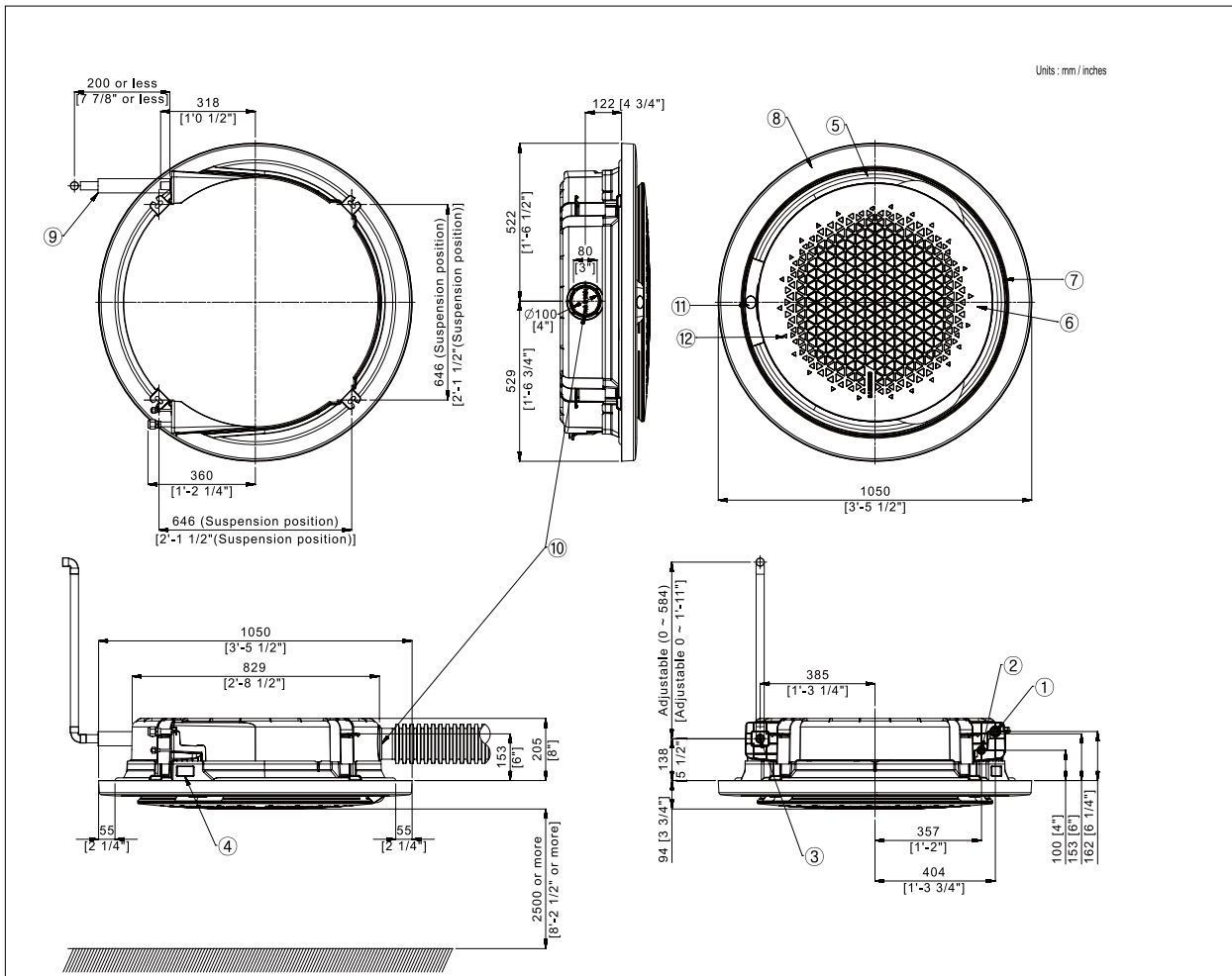

### Note

1. Make sure the spacing between the ceiling and the cassette is no more than 10mm[3/8"].
2. When the conditions exceed 30°C[86°F] and RH 80% in the ceiling or fresh air is induced into the ceiling, and additional insulation is required (polyethylene foam, thickness 10mm[3/8"] or more)
3. Open type panel model code : PC4NUNMAN
4. The circular panel is by default available in exposed installation.
5. Make inspection holes on the ceiling for easier installation and maintenance, as shown in the following table.  
(The size of an inspection hole must be at least 450 mm x 450 mm.)
6. A suspended ceiling structure can substitute for the inspection holes.

Category	Inspection hole		
	Recessed installation		Exposed installation
	Integrated	Suspended	
Square panel	1 ea		
Circular panel	2 ea		

### Table of descriptions

1	Refrigerant gas pipe	7	Suction rim for Booster fan
2	Refrigerant liquid pipe	8	Decoration cover
3	Condensate drain	9	Drain hose
4	Power & Comm. wiring conduits	10	Fresh air intake knock out hole
5	Air discharge opening	11	Display window
6	Air suction grille	12	Infrared receiver

# 3 Dimensional drawing

## 360 Cassette

AM112KN4DEH/EU, AM128KN4DEH/EU, AM140KN4DEH/EU

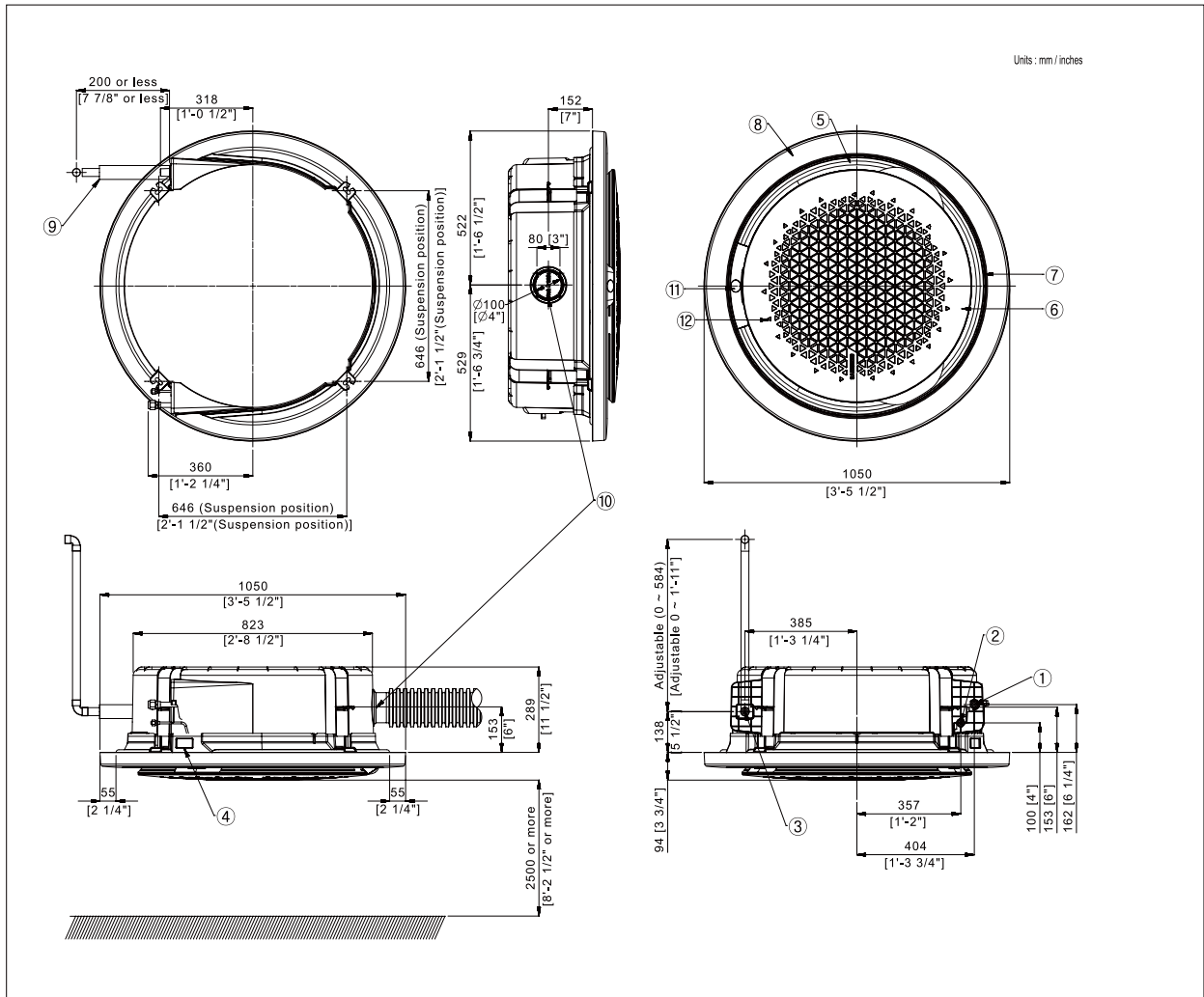

### Note

1. Make sure the spacing between the ceiling and the cassette is no more than 10mm[3/8"].
2. When the conditions exceed 30°C[86°F] and RH 80% in the ceiling or fresh air is induced into the ceiling, and additional insulation is required (polyethylene foam, thickness 10mm[3/8"] or more)
3. Open type panel model code : PC4NUNMAN
4. The circular panel is by default available in exposed installation.
5. Make inspection holes on the ceiling for easier installation and maintenance, as shown in the following table.  
(The size of an inspection hole must be at least 450 mm x 450 mm.)
6. A suspended ceiling structure can substitute for the inspection holes.

Category	Inspection hole		
	Recessed installation		Exposed installation
	Integrated	Suspended	
Square panel	1 ea		
Circular panel	2 ea		

### Table of descriptions

1	Refrigerant gas pipe	7	Suction rim for Booster fan
2	Refrigerant liquid pipe	8	Decoration cover
3	Condensate drain	9	Drain hose
4	Power & Comm. wiring conduits	10	Fresh air intake knock out hole
5	Air discharge opening	11	Display window
6	Air suction grille	12	Infrared receiver

# 4 Electrical wiring diagram

## 360 Cassette

AM045KN4DEH/EU, AM056KN4DEH/EU, AM071KN4DEH/EU, AM090KN4DEH/EU, AM112KN4DEH/EU, AM128KN4DEH/EU, AM140KN4DEH/EU

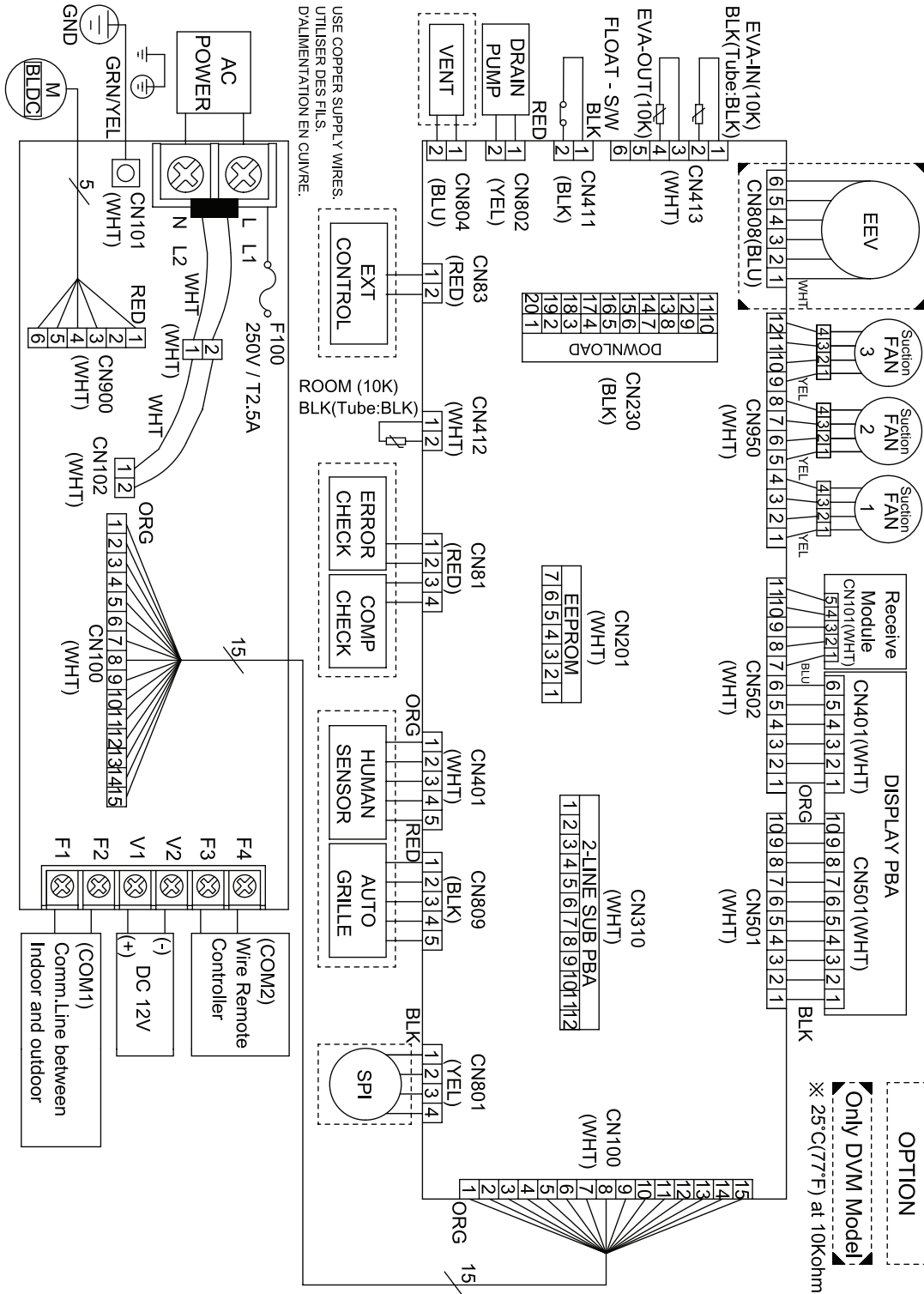



# 5 Sound pressure level

## 360 Cassette

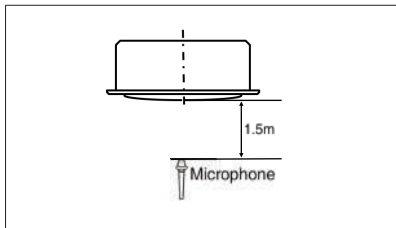

Unit: dB(A)

Model	High	Low
AM045KN4DEH/EU	33.0	29.0
AM056KN4DEH/EU	34.0	29.0
AM071KN4DEH/EU	36.0	30.0
AM090KN4DEH/EU	40.0	32.0

### Note

\* Specifications may be subject to change without prior notice

1) These operation values were obtained in an anechoic room.

2) Sound pressure level will vary depending on a range of factors such as the construction of the particular room

3) Operation sound level may differ depending on operation and ambient conditions.

## NC curve

### 1) AM045KN4DEH/EU

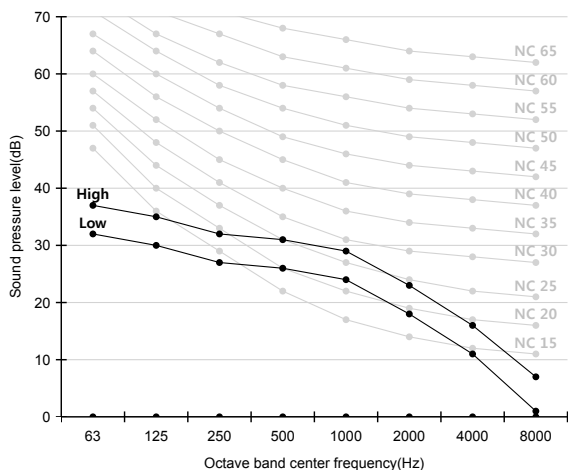

### 2) AM056KN4DEH/EU

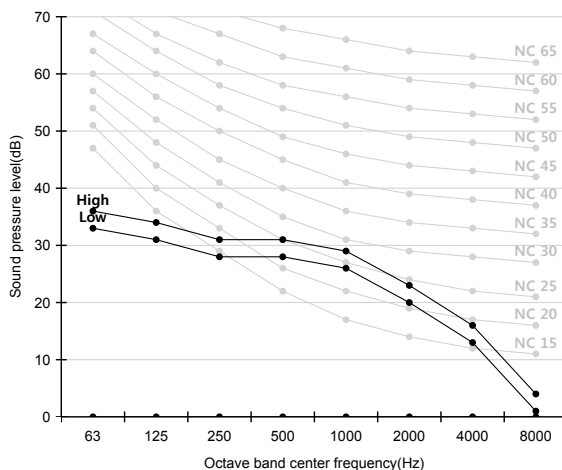

### 3) AM071KN4DEH/EU

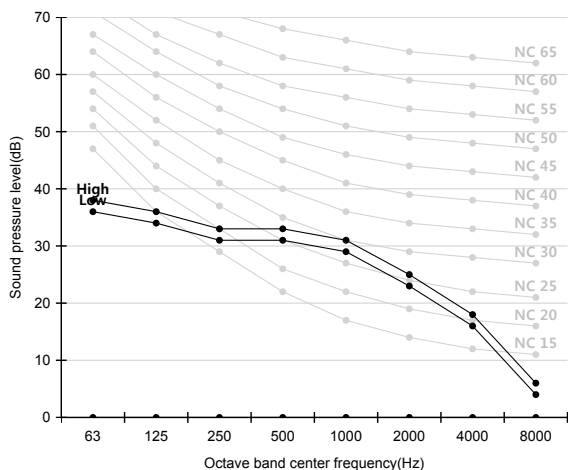

### 4) AM090KN4DEH/EU

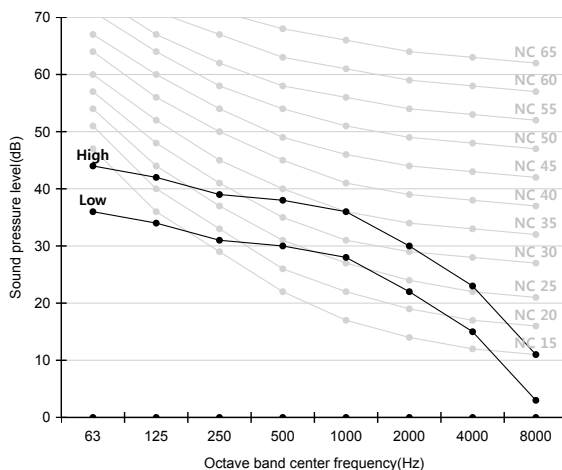

# 5 Sound pressure level

## 360 Cassette

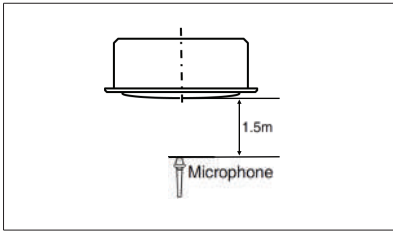

Unit: dB(A)

Model	High	Low
AM112KN4DEH/EU	40.0	32.0
AM128KN4DEH/EU	42.0	33.0
AM140KN4DEH/EU	44.0	35.0

### Note

\* Specifications may be subject to change without prior notice

1) These operation values were obtained in an anechoic room.

2) Sound pressure level will vary depending on a range of factors such as the construction of the particular room

3) Operation sound level may differ depending on operation and ambient conditions.

## NC curve

### 1) AM112KN4DEH/EU

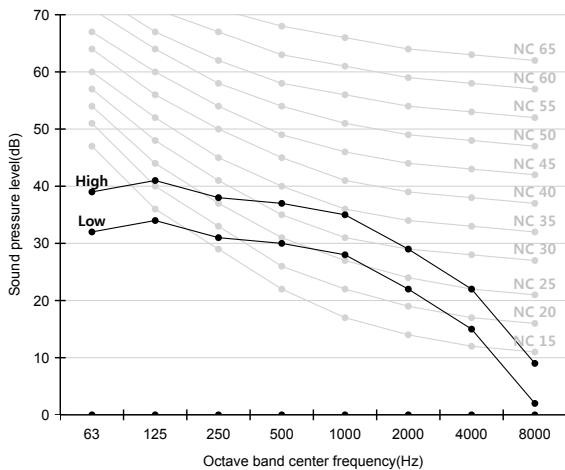

### 2) AM128KN4DEH/EU

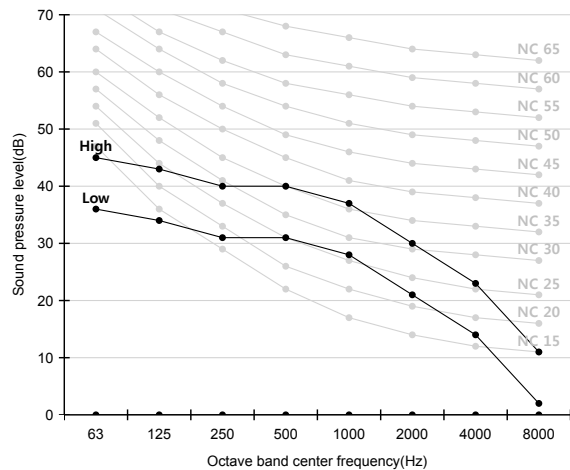

### 3) AM140KN4DEH/EU

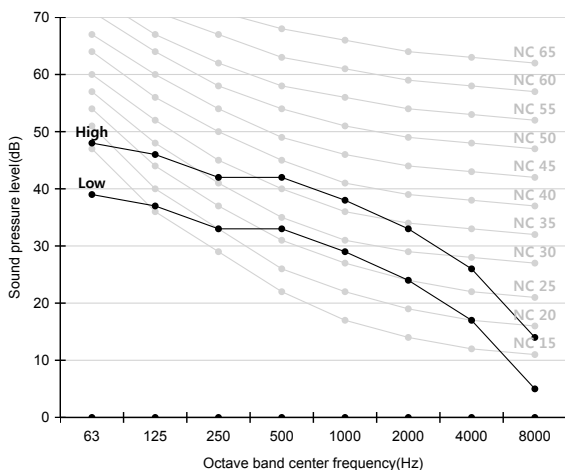

# 6 Sound power level

## 360 Cassette

### Note

- \* Specifications may be subject to change
- 1) dBA = A-weighted sound power level.
- 2) Reference power : 1pW.
- 3) Measured according to ISO 3741.

Unit: dB(A)

Model	Power
AM045KN4DEH/EU	50
AM056KN4DEH/EU	51
AM071KN4DEH/EU	53
AM090KN4DEH/EU	57

### 1)AM045KN4DEH/EU

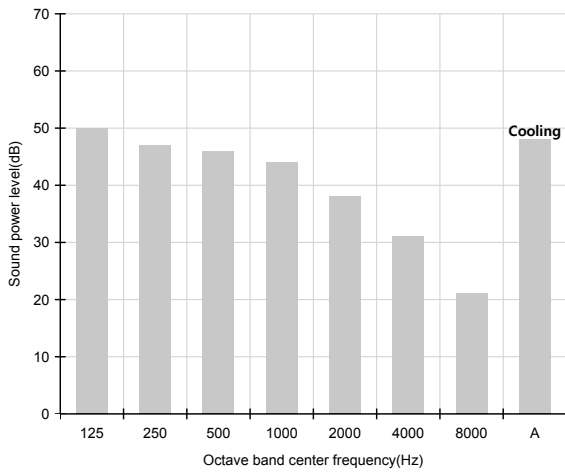

### 2)AM056KN4DEH/EU

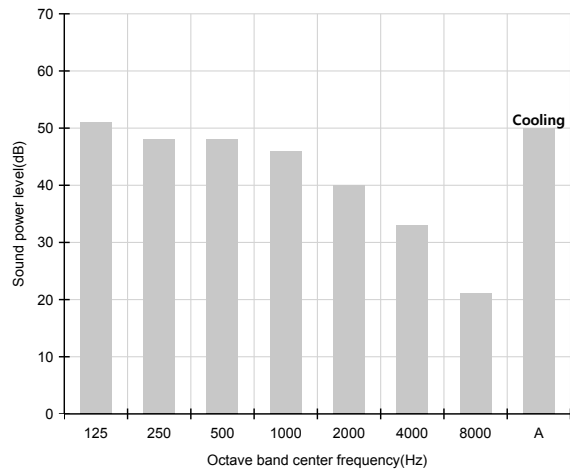

### 3)AM071KN4DEH/EU

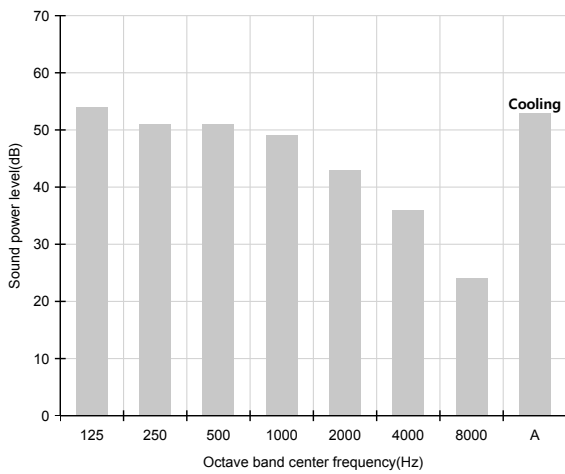

### 4)AM090KN4DEH/EU

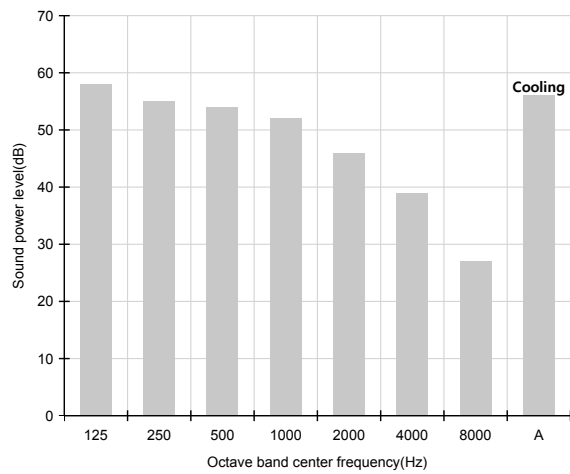

# 6 Sound power level

## 360 Cassette

### Note

- \* Specifications may be subject to change
- 1) dBA = A-weighted sound power level.
- 2) Reference power : 1pW.
- 3) Measured according to ISO 3741.

Unit: dB(A)

Model	Power
AM112KN4DEH/EU	58
AM128KN4DEH/EU	60
AM140KN4DEH/EU	61

### 1)AM112KN4DEH/EU

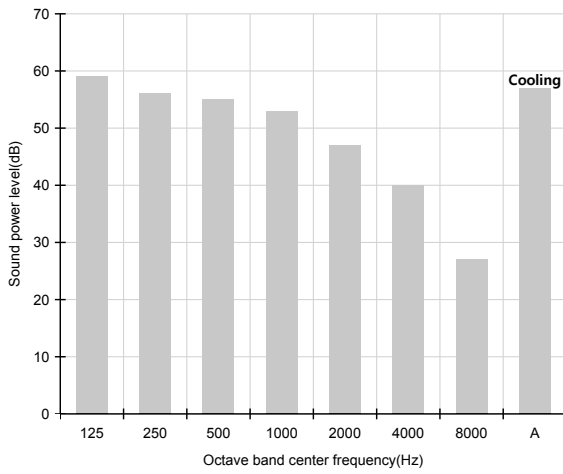

### 2)AM128KN4DEH/EU

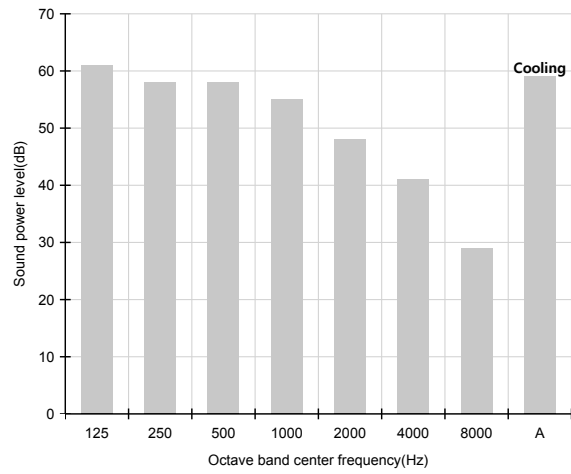

### 3)AM140KN4DEH/EU

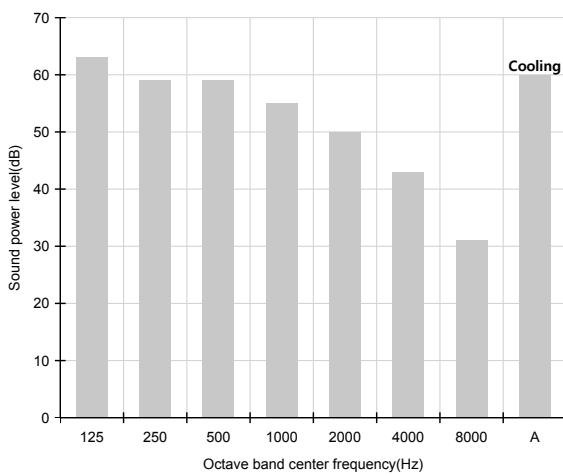

# 7 Temperature and air flow distribution

## 360 Cassette

AM045KN4DEH/EU

(1) Cooling air velocity distribution

Discharge angle : 60°

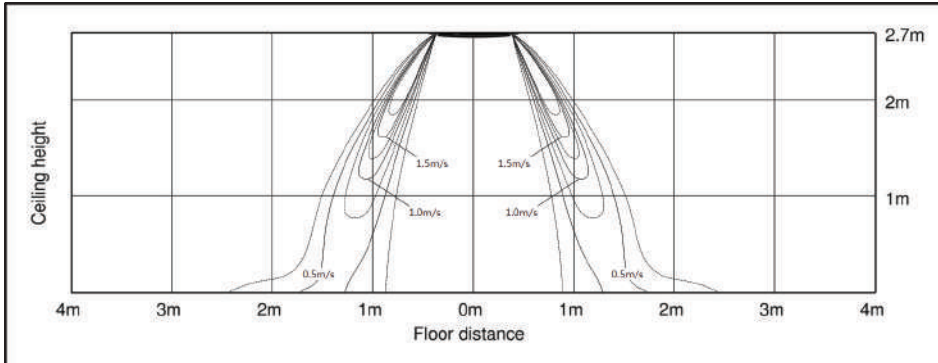

(2) Cooling temperature distribution

Discharge angle : 60°

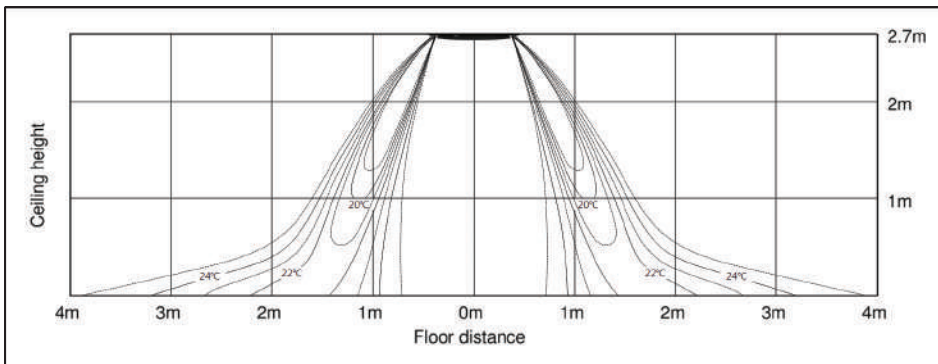

(3) Heating air velocity distribution

Discharge angle : 60°

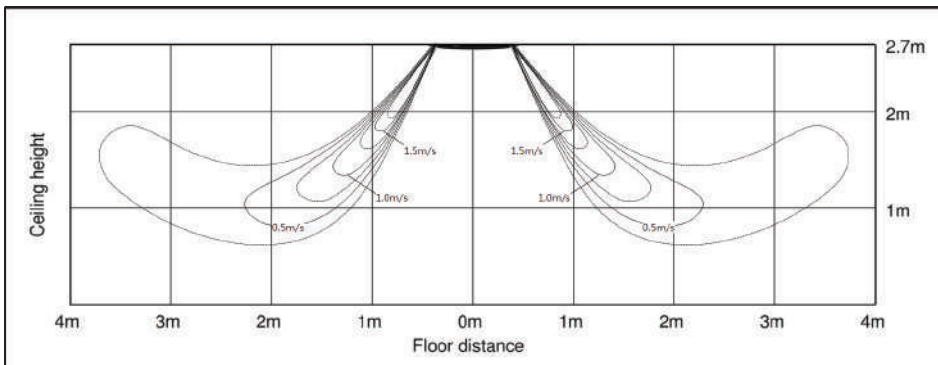

(4) Heating temperature distribution

Discharge angle : 60°

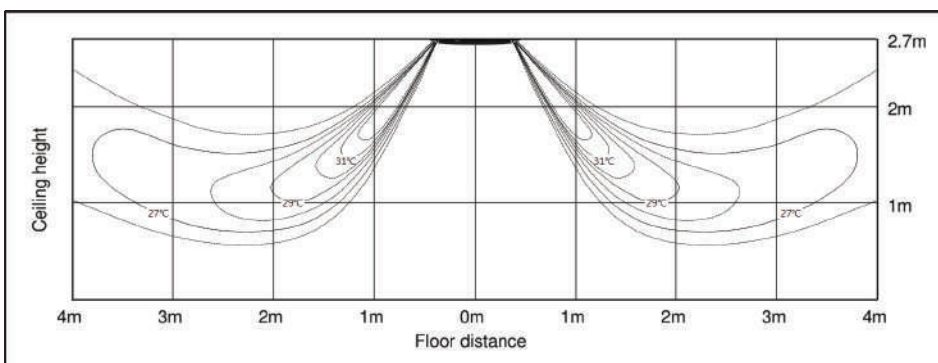

# 7 Temperature and air flow distribution

## 360 Cassette

AM056KN4DEH/EU

(1) Cooling air velocity distribution

Discharge angle : 60°

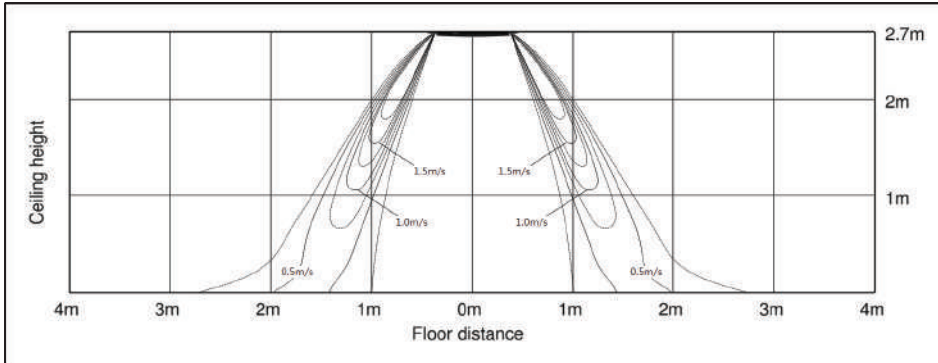

(2) Cooling temperature distribution

Discharge angle : 60°

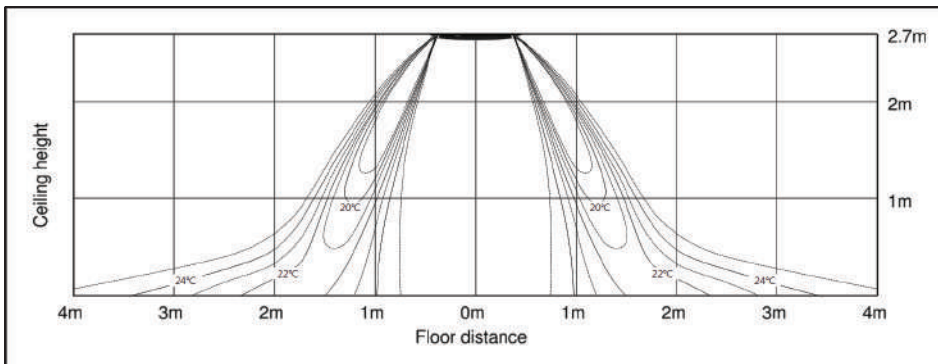

(3) Heating air velocity distribution

Discharge angle : 60°

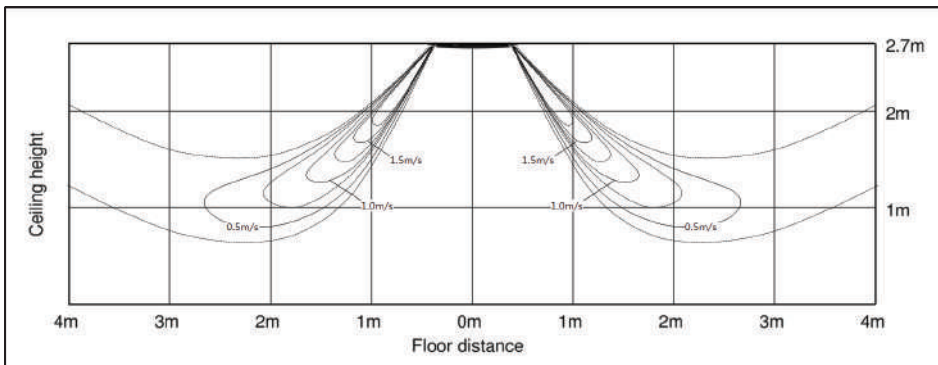

(4) Heating temperature distribution

Discharge angle : 60°

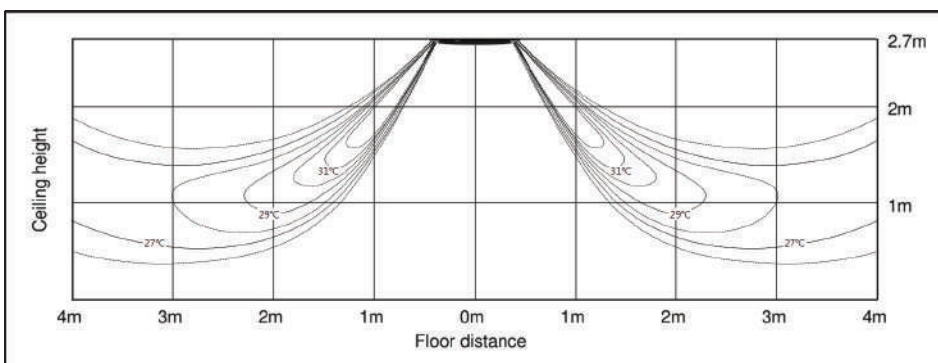

# 7 Temperature and air flow distribution

## 360 Cassette

AM071KN4DEH/EU

(1) Cooling air velocity distribution

Discharge angle : 60°

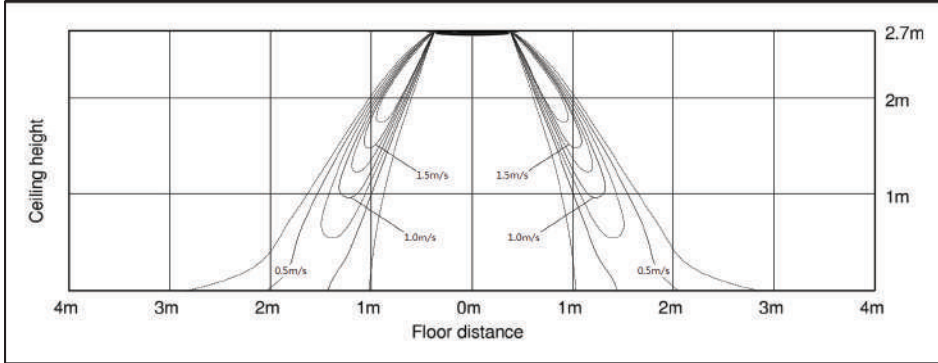

(2) Cooling temperature distribution

Discharge angle : 60°

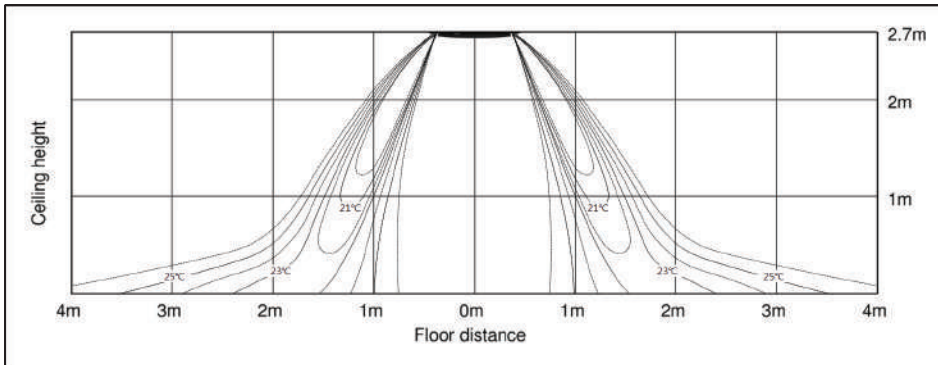

(3) Heating air velocity distribution

Discharge angle : 60°

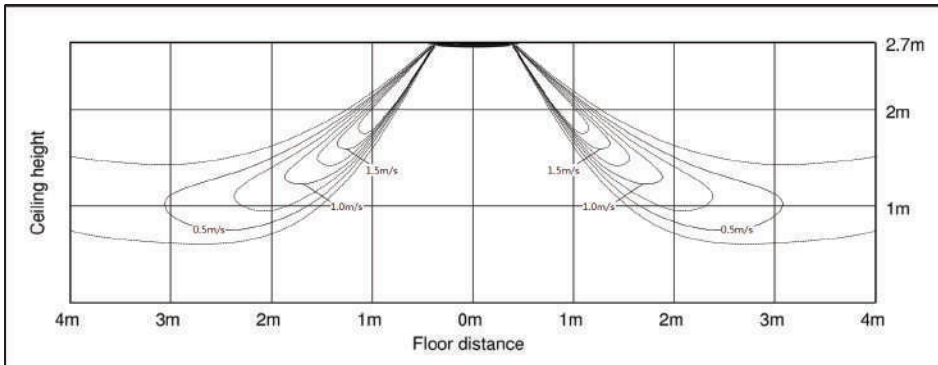

(4) Heating temperature distribution

Discharge angle : 60°

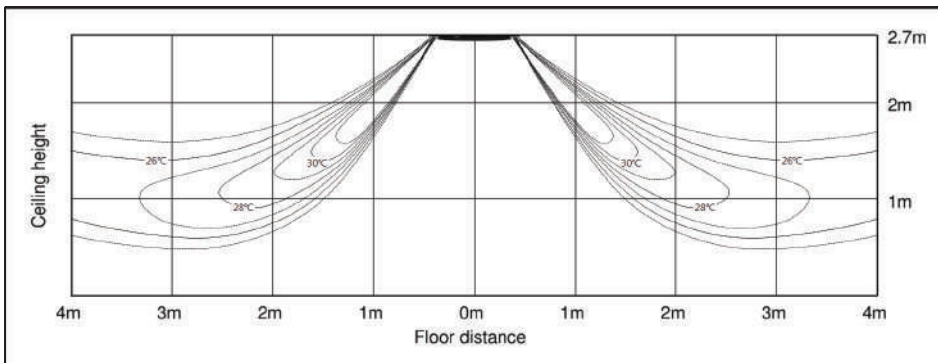

# 7 Temperature and air flow distribution

## 360 Cassette

AM090KN4DEH/EU

(1) Cooling air velocity distribution

Discharge angle : 60°

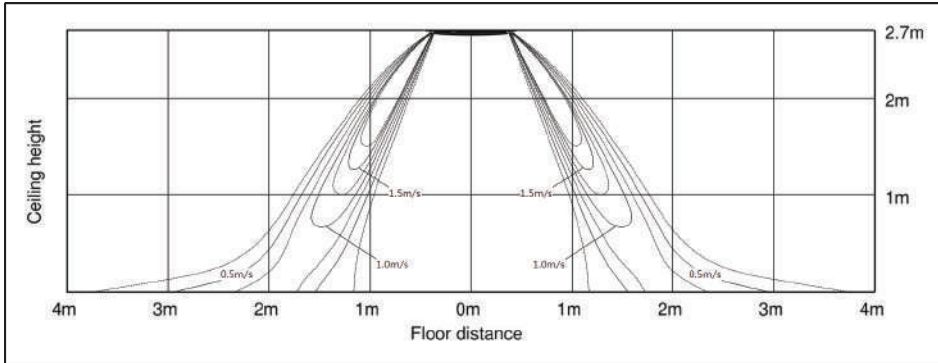

(2) Cooling temperature distribution

Discharge angle : 60°

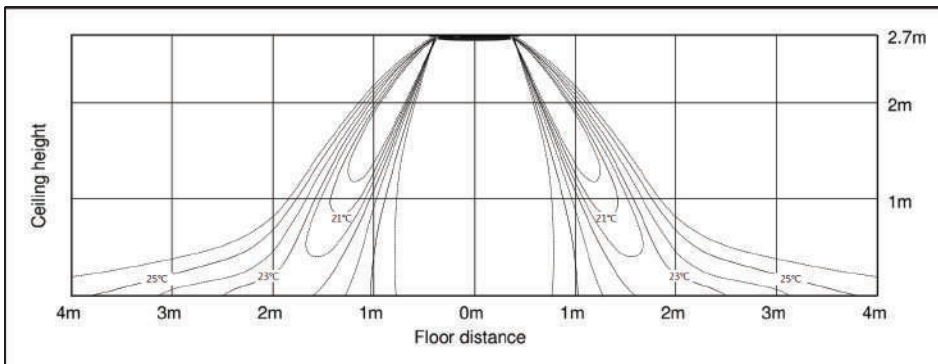

(3) Heating air velocity distribution

Discharge angle : 60°

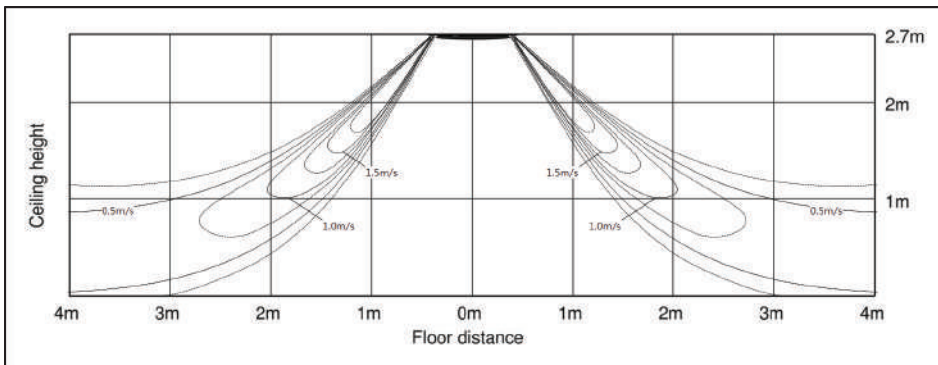

(4) Heating temperature distribution

Discharge angle : 60°

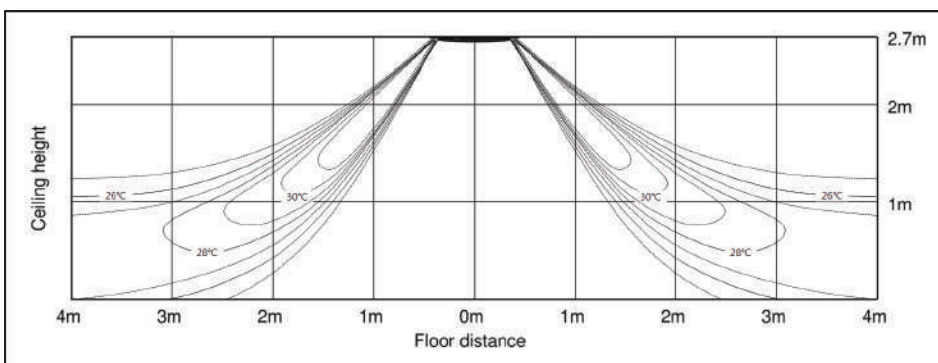



# 7 Temperature and air flow distribution

## 360 Cassette

AM112KN4DEH/EU

(1) Cooling air velocity distribution

Discharge angle : 60°

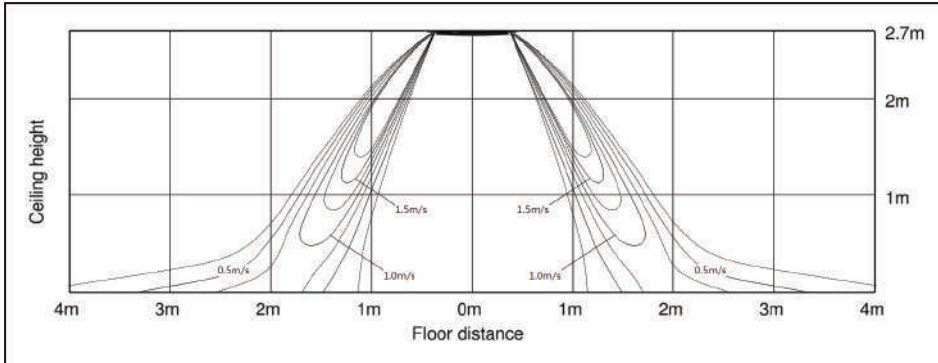

(2) Cooling temperature distribution

Discharge angle : 60°

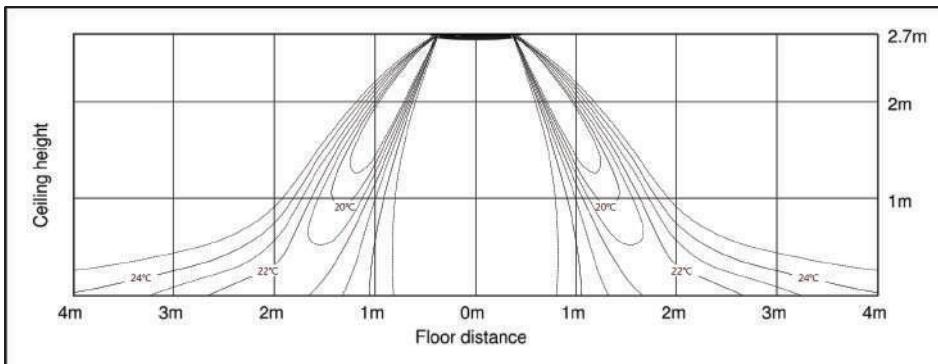

(3) Heating air velocity distribution

Discharge angle : 60°

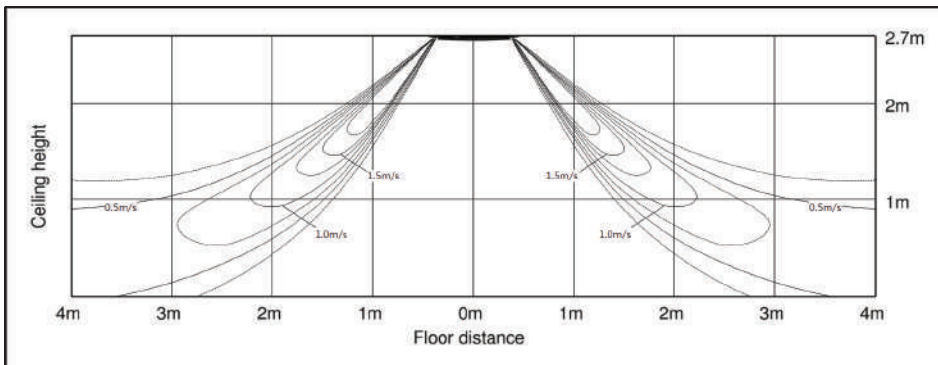

(4) Heating temperature distribution

Discharge angle : 60°

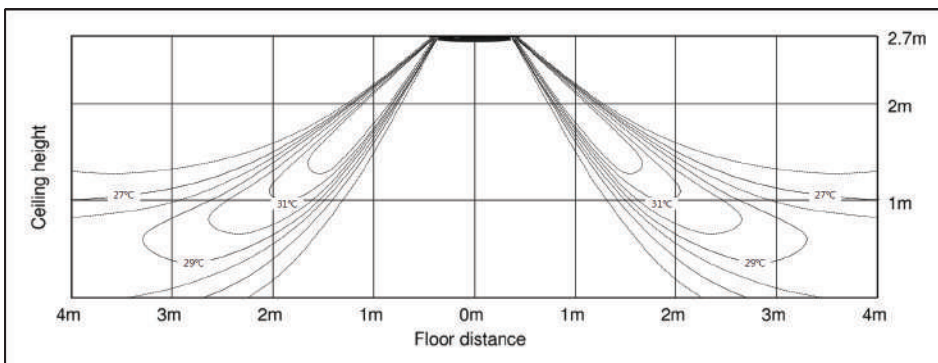

# 7 Temperature and air flow distribution

## 360 Cassette

AM128KN4DEH/EU

(1) Cooling air velocity distribution

Discharge angle : 60°

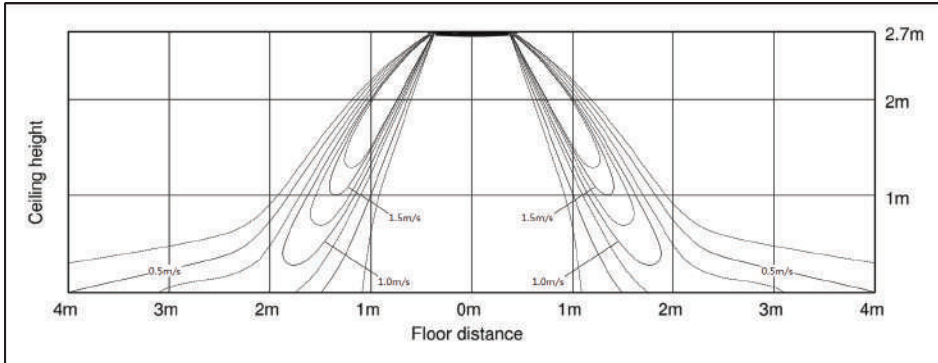

(2) Cooling temperature distribution

Discharge angle : 60°

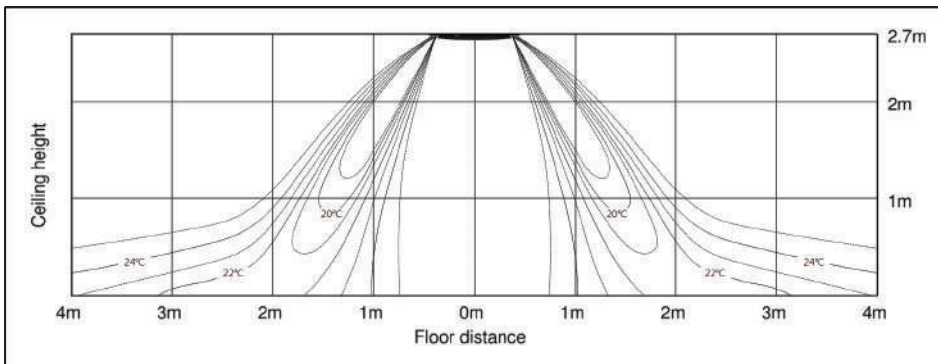

(3) Heating air velocity distribution

Discharge angle : 60°

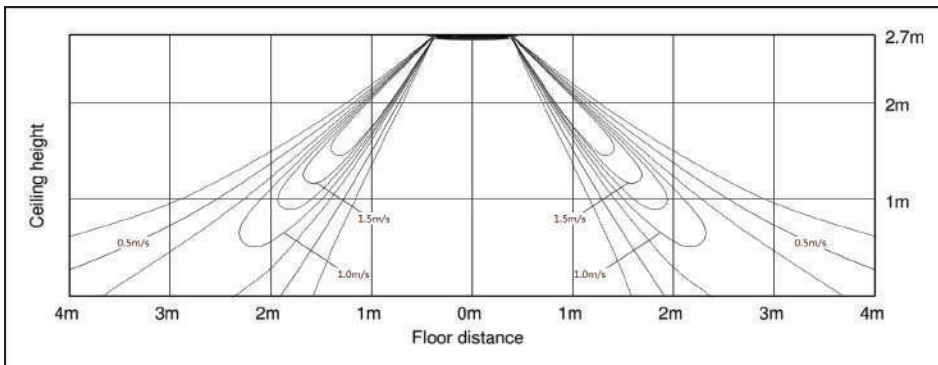

(4) Heating temperature distribution

Discharge angle : 60°

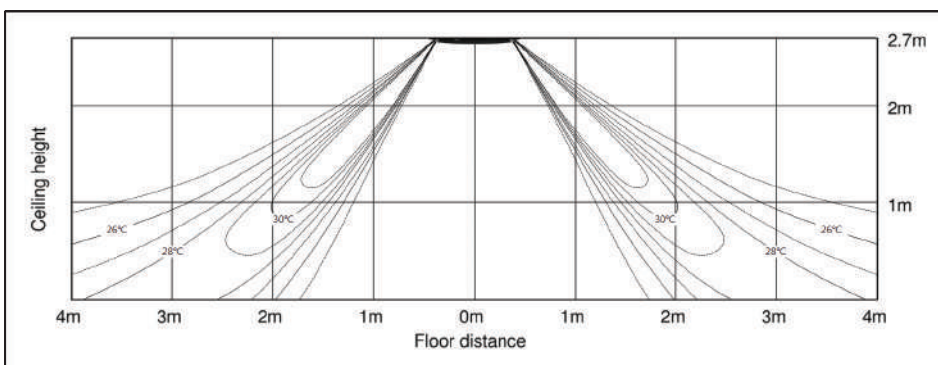

# 7 Temperature and air flow distribution

## 360 Cassette

AM140KN4DEH/EU

(1) Cooling air velocity distribution

Discharge angle : 60°

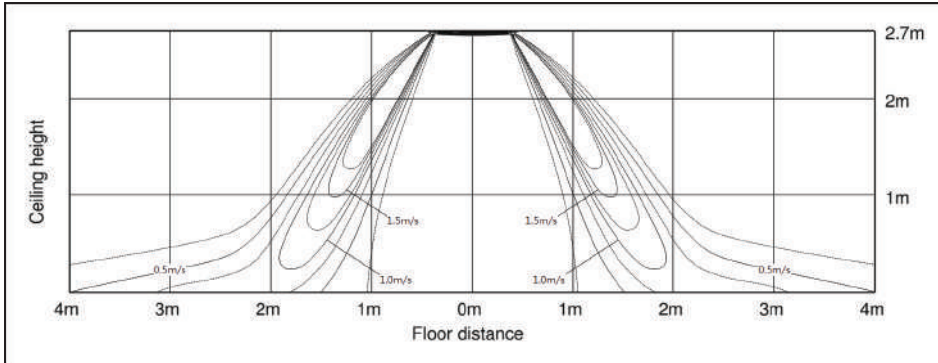

(2) Cooling temperature distribution

Discharge angle : 60°

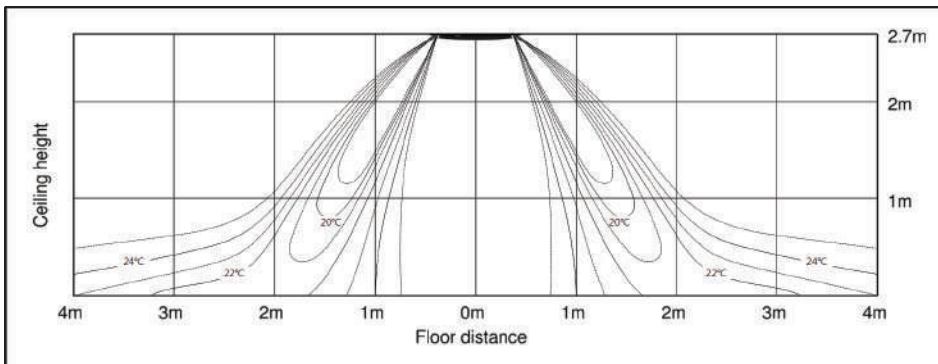

(3) Heating air velocity distribution

Discharge angle : 60°

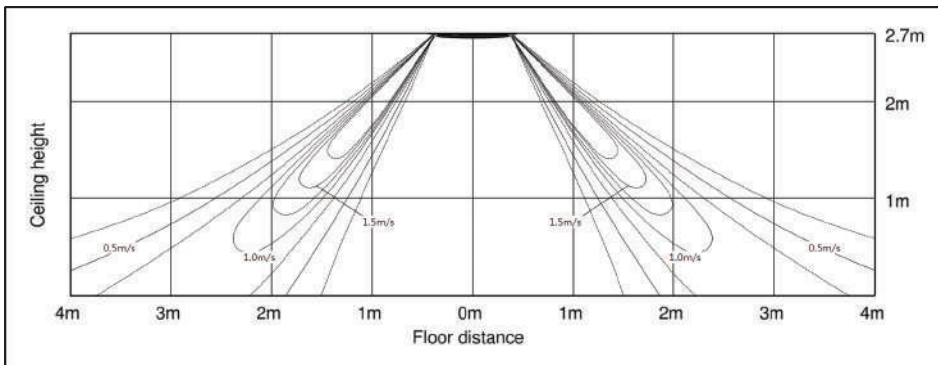

(4) Heating temperature distribution

Discharge angle : 60°

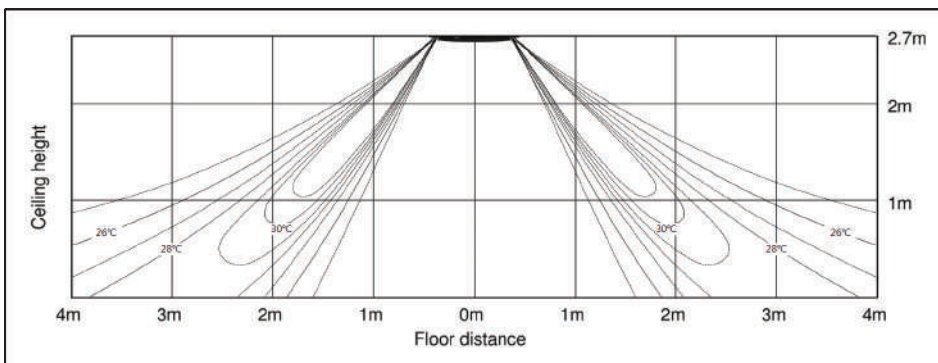



# 2 Capacity table

## 360 Cassette

### Cooling

TC : Total Capacity, SHC : Sensible Heat Capacity

Model	Outdoor Air Temp. (DB)	Indoor temperature													
		20 (°C, DB) 14 (°C, WB)		23 (°C, DB) 16 (°C, WB)		26 (°C, DB) 18 (°C, WB)		27 (°C, DB) 19 (°C, WB)		28 (°C, DB) 20 (°C, WB)		30 (°C, DB) 22 (°C, WB)		32 (°C, DB) 24 (°C, WB)	
		TC(kW)	SHC(kW)	TC(kW)	SHC(kW)	TC(kW)	SHC(kW)	TC(kW)	SHC(kW)	TC(kW)	SHC(kW)	TC(kW)	SHC(kW)	TC(kW)	SHC(kW)
12.80	10.0	8.80	7.30	10.40	8.10	12.00	9.00	12.80	9.10	13.30	9.10	14.30	9.10	15.40	9.10
	12.0	8.80	7.30	10.40	8.10	12.00	9.00	12.80	9.10	13.30	9.10	14.30	9.10	15.30	9.00
	14.0	8.80	7.30	10.40	8.10	12.00	9.00	12.80	9.10	13.30	9.10	14.30	9.10	15.30	9.00
	16.0	8.80	7.30	10.40	8.10	12.00	9.00	12.80	9.10	13.30	9.10	14.20	9.00	15.20	8.90
	18.0	8.80	7.30	10.40	8.10	12.00	9.00	12.80	9.10	13.30	9.10	14.20	9.00	15.10	8.80
	20.0	8.80	7.30	10.40	8.10	12.00	9.00	12.80	9.10	13.30	9.10	14.20	9.00	15.10	8.80
	21.0	8.80	7.30	10.40	8.10	12.00	9.00	12.80	9.10	13.30	9.10	14.20	9.00	15.10	8.80
	23.0	8.80	7.30	10.40	8.10	12.00	9.00	12.80	9.10	13.30	9.10	14.20	9.00	15.10	8.80
	25.0	8.80	7.30	10.40	8.10	12.00	9.00	12.80	9.10	13.30	9.10	14.20	9.00	15.10	8.80
	27.0	8.80	7.30	10.40	8.10	12.00	9.00	12.80	9.10	13.30	9.10	14.20	9.00	15.10	8.80
	29.0	8.80	7.30	10.40	8.10	12.00	9.00	12.80	9.10	13.30	9.10	14.20	9.00	15.10	8.80
	31.0	8.80	7.30	10.40	8.10	12.00	9.00	12.80	9.10	13.30	9.10	14.20	9.00	15.10	8.80
	33.0	8.80	7.30	10.40	8.10	12.00	9.00	12.80	9.10	13.30	9.10	14.20	9.00	15.10	8.80
	35.0	8.80	7.30	10.40	8.10	12.00	9.00	12.80	9.10	13.30	9.10	14.20	9.00	15.10	8.80
	37.0	8.80	7.30	10.40	8.10	12.00	9.00	12.80	9.10	13.20	9.00	14.00	8.90	14.90	8.70
39.0	8.80	7.30	10.40	8.10	12.00	9.00	12.80	9.20	13.10	8.90	13.80	8.80	14.50	8.60	
14.00	10.0	9.70	7.70	11.40	8.50	13.10	9.40	14.00	9.60	14.60	9.60	15.70	9.50	16.80	9.70
	12.0	9.70	7.70	11.40	8.50	13.10	9.40	14.00	9.60	14.50	9.60	15.60	9.60	16.70	9.60
	14.0	9.70	7.70	11.40	8.50	13.10	9.40	14.00	9.60	14.50	9.60	15.60	9.60	16.70	9.60
	16.0	9.70	7.70	11.40	8.50	13.10	9.40	14.00	9.60	14.50	9.60	15.60	9.60	16.60	9.50
	18.0	9.70	7.70	11.40	8.50	13.10	9.40	14.00	9.60	14.50	9.60	15.50	9.50	16.60	9.50
	20.0	9.70	7.70	11.40	8.50	13.10	9.40	14.00	9.60	14.50	9.60	15.50	9.50	16.50	9.40
	21.0	9.70	7.70	11.40	8.50	13.10	9.40	14.00	9.60	14.50	9.60	15.50	9.50	16.50	9.40
	23.0	9.70	7.70	11.40	8.50	13.10	9.40	14.00	9.60	14.50	9.60	15.50	9.50	16.50	9.40
	25.0	9.70	7.70	11.40	8.50	13.10	9.40	14.00	9.60	14.50	9.60	15.50	9.50	16.50	9.40
	27.0	9.70	7.70	11.40	8.50	13.10	9.40	14.00	9.60	14.50	9.60	15.50	9.50	16.50	9.40
	29.0	9.70	7.70	11.40	8.50	13.10	9.40	14.00	9.60	14.50	9.60	15.50	9.50	16.50	9.40
	31.0	9.70	7.70	11.40	8.50	13.10	9.40	14.00	9.60	14.50	9.60	15.50	9.50	16.50	9.40
	33.0	9.70	7.70	11.40	8.50	13.10	9.40	14.00	9.60	14.50	9.60	15.50	9.50	16.50	9.40
	35.0	9.70	7.70	11.40	8.50	13.10	9.40	14.00	9.60	14.50	9.60	15.50	9.50	16.50	9.40
	37.0	9.70	7.70	11.40	8.50	13.10	9.40	14.00	9.60	14.50	9.60	15.40	9.40	16.30	9.20
39.0	9.70	7.70	11.40	8.50	13.10	9.40	14.00	9.60	14.40	9.40	15.10	9.30	15.90	9.00	

# 2 Capacity table

## 360 Cassette

### Heating

TC : Total Capacity

Model	Outdoor Air Temp. (°C)		Indoor temperature				
	DB	WB	16 (°C, DB) TC(kW)	18 (°C, DB) TC(kW)	20 (°C, DB) TC(kW)	22 (°C, DB) TC(kW)	24 (°C, DB) TC(kW)
4.50	-20.0	-21.0	3.10	3.10	2.90	2.90	2.90
	-17.0	-18.0	3.20	3.20	3.10	3.00	3.00
	-15.0	-16.0	3.30	3.30	3.20	3.10	3.00
	-12.0	-13.0	3.50	3.40	3.40	3.30	3.20
	-10.0	-11.0	3.70	3.60	3.60	3.50	3.50
	-7.0	-8.0	3.90	3.80	3.80	3.70	3.60
	-5.0	-6.0	4.10	4.00	4.00	3.90	3.70
	-3.0	-4.0	4.30	4.20	4.20	4.00	3.90
	0.0	-1.0	4.50	4.40	4.40	4.20	4.00
	3.0	2.2	4.70	4.70	4.60	4.40	4.20
	5.0	4.1	4.90	4.90	4.80	4.50	4.20
	7.0	6.0	5.10	5.10	5.00	4.60	4.20
	9.0	7.9	5.30	5.20	5.00	4.60	4.20
	11.0	9.8	5.50	5.20	5.00	4.60	4.20
	13.0	12.0	5.60	5.30	5.00	4.60	4.20
5.60	15.0	14.0	5.80	5.40	5.00	4.60	4.20
	-20.0	-21.0	3.90	3.80	3.80	3.70	3.70
	-17.0	-18.0	4.00	4.00	3.90	3.80	3.80
	-15.0	-16.0	4.20	4.10	4.00	3.90	3.80
	-12.0	-13.0	4.40	4.30	4.20	4.20	4.10
	-10.0	-11.0	4.60	4.60	4.50	4.40	4.40
	-7.0	-8.0	4.90	4.80	4.80	4.70	4.50
	-5.0	-6.0	5.20	5.10	5.00	4.90	4.70
	-3.0	-4.0	5.40	5.30	5.30	5.10	4.90
	0.0	-1.0	5.70	5.60	5.50	5.30	5.00
	3.0	2.2	5.90	5.90	5.80	5.60	5.30
	5.0	4.1	6.20	6.10	6.00	5.70	5.30
	7.0	6.0	6.50	6.40	6.30	5.80	5.30
	9.0	7.9	6.70	6.50	6.30	5.80	5.30
	11.0	9.8	6.90	6.60	6.30	5.80	5.30
13.0	12.0	7.10	6.70	6.30	5.80	5.30	
15.0	14.0	7.30	6.80	6.30	5.80	5.30	
7.10	-20.0	-21.0	4.90	4.90	4.80	4.70	4.70
	-17.0	-18.0	5.10	5.00	4.90	4.80	4.80
	-15.0	-16.0	5.30	5.20	5.10	4.90	4.80
	-12.0	-13.0	5.60	5.50	5.40	5.30	5.20
	-10.0	-11.0	5.90	5.80	5.70	5.60	5.60
	-7.0	-8.0	6.20	6.10	6.00	5.90	5.80
	-5.0	-6.0	6.50	6.50	6.40	6.20	6.00
	-3.0	-4.0	6.90	6.80	6.70	6.40	6.20
	0.0	-1.0	7.20	7.10	7.00	6.70	6.40
	3.0	2.2	7.60	7.50	7.30	7.10	6.80
	5.0	4.1	7.90	7.80	7.70	7.20	6.80
	7.0	6.0	8.20	8.10	8.00	7.40	6.80
	9.0	7.9	8.50	8.20	8.00	7.40	6.80
	11.0	9.8	8.70	8.40	8.00	7.40	6.80
	13.0	12.0	9.00	8.50	8.00	7.40	6.80
15.0	14.0	9.20	8.60	8.00	7.40	6.80	
9.00	-20.0	-21.0	6.00	6.00	5.90	5.80	5.80
	-17.0	-18.0	6.30	6.30	6.10	6.00	5.90
	-15.0	-16.0	6.70	6.50	6.30	6.10	6.00
	-12.0	-13.0	7.00	6.90	6.70	6.60	6.50
	-10.0	-11.0	7.30	7.20	7.10	7.00	7.00
	-7.0	-8.0	7.80	7.70	7.60	7.40	7.20
	-5.0	-6.0	8.20	8.10	8.00	7.70	7.50
	-3.0	-4.0	8.60	8.50	8.40	8.10	7.70
	0.0	-1.0	9.00	8.90	8.80	8.40	8.00
	3.0	2.2	9.40	9.30	9.20	8.80	8.40
	5.0	4.1	9.90	9.70	9.60	9.00	8.40
	7.0	6.0	10.30	10.10	10.00	9.20	8.40
	9.0	7.9	10.60	10.30	10.00	9.20	8.40
	11.0	9.8	10.90	10.50	10.00	9.20	8.40
	13.0	12.0	11.20	10.60	10.00	9.20	8.40
15.0	14.0	11.60	10.80	10.00	9.20	8.40	
11.20	-20.0	-21.0	7.40	7.40	7.30	7.30	7.30
	-17.0	-18.0	8.00	7.80	7.60	7.50	7.40
	-15.0	-16.0	8.40	8.10	7.90	7.70	7.50
	-12.0	-13.0	8.80	8.60	8.40	8.20	8.10
	-10.0	-11.0	9.20	9.00	8.90	8.80	8.70
	-7.0	-8.0	9.70	9.60	9.40	9.20	9.00
	-5.0	-6.0	10.20	10.10	9.90	9.60	9.30
	-3.0	-4.0	10.70	10.60	10.50	10.10	9.70
	0.0	-1.0	11.30	11.10	11.10	10.50	10.00
	3.0	2.2	11.80	11.60	11.50	11.00	10.60
	5.0	4.1	12.30	12.20	12.00	11.30	10.60
	7.0	6.0	12.90	12.70	12.50	11.50	10.60
	9.0	7.9	13.30	12.90	12.50	11.50	10.60
	11.0	9.8	13.70	13.10	12.50	11.50	10.60
	13.0	12.0	14.00	13.30	12.50	11.50	10.60
15.0	14.0	14.40	13.50	12.50	11.50	10.60	

# 2 Capacity table

## 360 Cassette

### Heating

TC : Total Capacity

Model	Outdoor Air Temp. (°C)		Indoor temperature				
			16 (°C, DB)	18 (°C, DB)	20 (°C, DB)	22 (°C, DB)	24 (°C, DB)
12.80	DB	WB	TC(kW)	TC(kW)	TC(kW)	TC(kW)	TC(kW)
	-20.0	-21.0	8.10	8.10	8.00	8.00	8.00
	-17.0	-18.0	8.70	8.50	8.40	8.30	8.10
	-15.0	-16.0	9.20	9.00	8.70	8.50	8.20
	-12.0	-13.0	9.70	9.50	9.30	9.10	8.90
	-10.0	-11.0	10.10	10.00	9.90	9.70	9.60
	-7.0	-8.0	10.70	10.60	10.40	10.20	10.00
	-5.0	-6.0	11.30	11.10	11.00	10.70	10.30
	-3.0	-4.0	11.90	11.70	11.50	11.10	10.70
	0.0	-1.0	12.40	12.30	12.10	11.60	11.00
	3.0	2.2	13.00	12.90	12.70	12.20	11.70
	5.0	4.1	13.60	13.40	13.20	12.40	11.70
	7.0	6.0	14.20	14.00	13.80	12.70	11.70
	9.0	7.9	14.60	14.20	13.80	12.70	11.70
	11.0	9.8	15.10	14.40	13.80	12.70	11.70
	13.0	12.0	15.50	14.70	13.80	12.70	11.70
	15.0	14.0	15.90	14.90	13.80	12.70	11.70
14.00	-20.0	-21.0	9.50	9.50	9.40	9.40	9.30
	-17.0	-18.0	10.00	9.90	9.60	9.60	9.40
	-15.0	-16.0	10.70	10.40	10.10	9.80	9.50
	-12.0	-13.0	11.20	11.00	10.80	10.60	10.30
	-10.0	-11.0	11.70	11.60	11.40	11.30	11.10
	-7.0	-8.0	12.40	12.20	12.10	11.80	11.50
	-5.0	-6.0	13.10	12.90	12.70	12.30	12.00
	-3.0	-4.0	13.80	13.60	13.40	12.90	12.40
	0.0	-1.0	14.40	14.20	14.00	13.40	12.80
	3.0	2.2	15.10	14.90	14.70	14.10	13.50
	5.0	4.1	15.80	15.60	15.30	14.40	13.50
	7.0	6.0	16.50	16.20	16.00	14.80	13.50
	9.0	7.9	17.00	16.50	16.00	14.80	13.50
	11.0	9.8	17.50	16.70	16.00	14.80	13.50
	13.0	12.0	18.00	17.00	16.00	14.80	13.50
	15.0	14.0	18.50	17.20	16.00	14.80	13.50