

# Samsung Built-In Kitchen Appliances 2017-2018



Samsung Built-In Kitchen Appliances 2017-2018



**SAMSUNG**

Brochure accurate at the time of printing.

**SAMSUNG**



## Contents

<b>Leading Innovation</b>	<b>4</b>
<b>Refrigeration</b>	<b>14</b>
Key innovation	15
Features	16
Models	18
<b>Ovens</b>	<b>22</b>
Features	24
Models	26
<b>Compact Ovens</b>	<b>30</b>
Features	31
Models	32
<b>Cooktop</b>	<b>36</b>
Features	38
Models	40
<b>Hoods</b>	<b>44</b>
Features	45
Models	46
<b>Dishwashers</b>	<b>50</b>
Features	51
Models	52
<b>Specifications</b>	<b>54</b>
<b>Installation Guide</b>	<b>66</b>
<b>Services</b>	<b>79</b>



Samsung Electronics is a global leader in technology, opening new possibilities for people everywhere through relentless innovation and discovery.

We believe technology should enable progress for all. That's why we always look to create and deliver quality products that enhance convenience and foster smarter lifestyles for our customers around the world.



**What if the  
best innovation  
and design was  
Built-In to your  
kitchen?**



## Introducing the new Samsung Built-In Kitchen Appliances

①



A refrigerator that allows you to convert the freezer zone to a fridge & vice versa.

Need more room to hold cool beverages for a party? Convert the freezer zone to an extra fridge compartment at the touch of a button.

See page 15 for more information.

②



An oven that lets you cook two totally different dishes at the same time.

Prepare two different dishes at different temperatures, with different settings, at the same time.

See page 27 for more information.

③



An induction cooktop that projects a virtual flame onto your cookware.

Enjoy the benefit of seeing a visible flame to better control the heat.

See page 38 for more information.

④



A dishwasher that uses sweeping walls of water to thoroughly wash your dishes.

Say goodbye to tough food residues and say hello to sparkling clean dishes from corner to corner.

See page 51 for more information.



## Introducing the new Samsung Built-In Kitchen Appliances

The world is full of appliances with 'smart technologies.' But if those technologies don't help improve your day-to-day life, they are not that smart.

At Samsung, we don't just design our kitchen appliances around the latest technologies, we design them around you because we know that home is your making. And as we're all unique, we know that no two homes are the same.

Our products are designed with four core values in mind:

### Innovation

Our products contain unique, new-to-the-world innovations to make your time in the kitchen that much more enjoyable. No matter what you choose to cook, clean or preserve, we make sure our appliances offer practical and efficient solutions.

### Flexibility

Our products are designed to give you maximum flexibility to fit not only your kitchen's style but your own. All the versatility you need to give you full control over any meals you prepare, food you want to store and dishes that need washing.

### Design

Our extensive range of Built-In products have all been thoughtfully designed to provide the perfect solution for you, no matter what type of kitchen you have. Our products are inspired by the designs of premium kitchens – sleek, minimalist, and modern – while still being functional and easy-to-use.

### Reliability

Not only do we take pride in our design and innovations across all our products, but we are also committed to ensuring there are no compromises when it comes to the dependability and durability of our products.



## Reflecting today's modernity and practical needs in our pioneering appliances.

Choose Samsung Smart Technology to free up some of your time.

### ① Smarter Control - WiFi Connection

Enjoy simply smarter control anytime and anywhere with a smart phone.\*

Samsung Built-In Oven's WiFi Connection lets you **remotely monitor and control** the oven using an app\* on your smartphone. **From anywhere inside or outside the house**, you can easily check and change settings and adjust cooking times and temperatures. It also helps you to cook like a professional by selecting a Chef Recipe recommended by Michelin 3-Star Chefs.

\*Requires Smart Home App, available on Android and iOS.

#### 1. Monitoring & notification

- Monitor cooking mode, time and temperature.
- Receive notification for preheating, cooking, and error code.
- View the manual on mobile phone.
- Check the temperature of meat probe.

#### 2. Simple remote control

- Turn off the power.
- Control cook time and temperature.

#### 3. Recipe download and setting

- Find recipes by Michelin 3-Star Chefs and easily use them at home.

\*Available on Android and iOS devices. A network connection is required.

### ② Smarter Control - Smart Dongle

Control anytime and anywhere.

Samsung Built-In Refrigerator is WiFi capable. Using the optional Samsung Smart Dongle and App\*, you can check what it's doing remotely on your smartphone, allowing you to control its rapid cooling modes, monitor the temperature and receive alerts if the door is left open. It even diagnoses errors so you don't have to read the manual.

\*Dongle sold separately. Smart Home App is available on Android and iOS. A network connection is required.

#### Smart Manager

##### Remote Door Alarm

Accidents happen. Leaving a door open on your refrigerator can result in food spoiling quickly, unnecessary wastage and unwanted expense. But thanks to our clever technology, with the Samsung BRB6000, this becomes a thing of the past. If a door is accidentally left open, the refrigerator will sound an audible alarm. If the door remains open for more than 2 minutes, a warning notification is then sent via the App\* to your smartphone, alerting you to close the door.

\*Smart Home App, available on Android and iOS.

##### Rapid Cooling

Providing the optimum cooling environment for your food means your food will stay fresher and taste better for longer. The Rapid Cooling function enables you to remotely control and set the fridge and freezer compartment temperatures to the lowest level before you get home – ideal if you are returning from the Supermarket with your shopping.

# Refrigeration

Enjoy ultimate storage flexibility and superior cooling technology with Samsung's wide range of Fridge Freezers.



## Twin Cooling Plus™

Twin Cooling Plus™ technology creates the optimal temperature and humidity in the fridge and freezer. This not only preserves food in the best condition, it also protects its natural flavour and aroma. It cools each compartment independently and prevents odours from mixing between them using their own dedicated evaporators and cooling systems. As a result, it retains more moisture and maintains a high humidity level all over the fridge. So, even the most perishable fruits and vegetables are kept fresher for longer, without them drying out or needing to be wrapped, which helps to reduce waste.

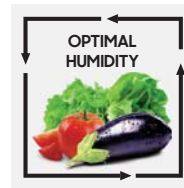

### Optimal Humidity

Thanks to the Twin Cooling Plus™, the fridge compartment has its own dedicated supply of cold air, which maintains an optimal level of humidity.

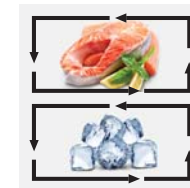

### No Odour Mixing

Twin Cooling Plus™ system cools the compartments separately to stop unpleasant odours spreading from fridge to freezer, so frozen food retains more natural flavour without being tainted by smells from the fridge.



### Flexibility

The CoolSelect Plus zone provides the ultimate in flexibility for different foods to be stored at the optimum temperature. That way, everything stays fresher and tastes great. With one touch, the bottom compartment can be easily converted from a freezer to fridge using the optimal pre-set temperatures of 2°C, -1°C, -5°C or -23°C to -15°C.



# Features



## No Frost

Why defrost a fridge? Our Total No Frost feature maintains an even temperature, preventing ice build-up and saving you the hassle of defrosting.



## CoolSelect Plus Zone

The CoolSelect Plus Zone provides the ultimate in flexibility for different foods to be stored at the optimum temperature. That way, everything stays fresher and tastes great. With one touch, the bottom compartment can be easily converted from a freezer to fridge using the optimal pre-set temperatures of 2°C, -1°C, -5°C or -23°C to -15°C.



## Metal Cooling

The Metal Cooling Plate in the rear wall helps to retain the cold and maintain the optimal temperature within the fridge by restoring any heat loss, so your food is preserved better, even if you frequently open and close the door. It also adds a beautiful, premium look and is very easy to wipe clean.



## Precise Chef Cooling™

Chefs say that precise and stable temperature control is the key to keeping food at its freshest. Precise Chef Cooling™ minimises temperature fluctuation, so all of your ingredients retain their original textures and flavours.



## Fresh Zone

Fresh Zone is a smartly designed drawer that provides the ideal environment for preserving meat and fish, keeping them at the optimum temperature so they stay fresh and have the best possible flavour.



## SpaceMax Technology™

SpaceMax Technology™ creates extra internal capacity by using a slim wall design, without compromising energy efficiency.



## The Digital Inverter Compressor™

The Digital Inverter Compressor™ automatically adjusts its speed in response to cooling demand across 7 levels. This helps use less energy, minimise noise and reduce wear and tear for a longer-lasting performance. And for complete peace of mind, its performance is backed up by a 10 year warranty\*.



## Take-Out Tray

Quickly see what's inside thanks to the transparent Take-Out Tray. Ideal to easily store and access all of your favourite or frequently used food items.



## Easy Slide Shelf

Reaching into your freezer often will no longer mean navigating an obstacle course of items. The Easy Slide Shelf simply slides in and out so you can efficiently store, organise and access your frozen food to find and reach things at the back and in every corner, with no "dead space".



## Adjustable Door Pockets

Adjustable Door Pockets help you easily organise and flexibly store differently sized items. You can adjust the pockets to fit all sizes of bottles, cartons and other items for maximum use of your storage space.



## Dongle with WiFi Ready

Smart Dongle allows you to control Power Freeze & Cool functions, monitor the energy usage and Door Alarm right from your smartphone\*.

\*Requires Smart Home App, available on Android and iOS.

# Models

## Built-In Fridge Freezers

The Samsung BRB6000 range of Built-In Fridge Freezers preserve the original freshness, flavour and texture of food for longer with advanced cooling systems that optimise the temperature and humidity, retain the cold and prevent ice build up. And you can remotely monitor and control it from anywhere at any time with Smart Dongle and App\*.



### BRB260087WW

#### Key features

- Twin Cooling Plus™
- CoolSelect Plus
- Metal Cooling
- 263L Capacity
- SpaceMax Technology™
- Precise Chef Cooling
- Adjustable Door Pocket
- Fresh Zone
- Premium Finishing
- No Frost
- Energy Class A++
- Digital Inverter Technology™
- Slide Door
- Power Cool & Freeze

#### Included accessories

- Egg Container
- Ice Maker (Tray)
- Wine Rack
- Take Out Tray



### BRB260130WW

#### Key features

- All Around Cooling
- 267L Capacity
- SpaceMax Technology™
- Adjustable Door Pocket
- Premium Finishing
- No Frost
- Energy Class A+
- Digital Inverter Technology™
- Fixed Door
- Power Freeze

#### Included accessories

- Egg Container
- Ice Maker (Tray)
- Wine Rack



### BRB260000WW

#### Key features

- All Around Cooling
- 268L Capacity
- SpaceMax Technology™
- Adjustable Door Pocket
- No Frost
- Energy Class A+
- Digital Inverter Technology™
- Slide Door
- Power Freeze

#### Included accessories

- Egg Container
- Ice Maker (Tray)

# Models

## Freestanding Fridge Freezers

Size. Capacity. Efficiency. All Fridges are the same, right? Wrong. Samsung fridges are different. Our refrigerators are not only beautifully designed to be spacious and versatile, and enhance the look of your kitchen. They also include unique touches – clever features that help you in the life you lead. It's time to take a fresh look at your next fridge and open the door to one designed for the way you want to live. Open the door to fresh thinking.



### RF56M9540SR

#### Key features

- Family Hub™ Display
- CoolSelect Plus Zone
- Triple Cooling
- 635L Capacity
- 380L Fridge
- 255L Freezer
- No Frost
- Energy Class A+

#### Included accessories

- Egg container
- Ice Maker (Integrated)



### RF23M8080SR

#### Key features

- Twin Cooling
- FlexZone Drawer
- 636L Capacity
- 449L Fridge
- 187L Freezer
- No Frost
- Energy Class A+

#### Included accessories

- Egg container
- Ice Maker (Integrated)



### RS7667FHCBC

#### Key features

- Twin Cooling
- 580L Capacity
- 365L Fridge
- 215L Freezer
- No Frost
- Energy Class A+

#### Included accessories

- Egg container
- Ice Maker (Integrated)



### RZ32M71207F/RR39M73407F

#### Key features

- Paired or individual
- Pairing kit included
- 745L Combined Capacity
- 390L Fridge
- 355L Freezer
- No Frost
- Energy Class A+

#### Included accessories

- Egg container
- Water Dispenser (Non plumbed)
- Wine rack
- Slim Ice Maker

# Oven

Samsung Built-In Ovens are designed for people who want eye-catching style and great results, with the minimum of effort. With Dual Cook technology, you can cook multiple dishes at once and all with the precision needed for professional-quality food.



# Features



## Meat Probe

A Meat Probe allows you to monitor the internal food temperature without any guesswork by clearly indicating when meat is thoroughly cooked, all without opening the oven door and releasing heat.



## Soft Closing Door

The Soft Closing Door smoothly and gently opens and closes with minimal noise. The door hinge helps it to slowly come to a stop safely, giving you complete peace of mind.



## Guide Lighting Control

You can control cooking temperatures and times, select functions and set cleaning options easily with an intuitive step-by-step display. By following the lights it clearly shows you what to do next, based on the last option you chose, so you can prepare delicious meals without reaching for the instruction manual.



## Real Steam Cooking

Get your meal just right with Real Steam Cooking. It is a healthy way to roast and bake, keeping fat and salt levels low, and preventing foods from drying out. Moreover, Real Steam Cooking makes your favourite food have a beautiful golden brown crust with crispy texture while keeping moisture inside.



## Full Touch Colour LCD Control

A 4.6" full-touch LCD display offers a much simpler and easier way to cook – exactly how you want to. You can select and control a range of functions and settings, such as cooking mode, temperature and time, with the simple touch of your finger.



## Telescopic Rail

A Telescopic Rail slides in and out smoothly with hardly any effort, even if you're using large pans or heavy dishes. So you can keep on basting, turning and seasoning your food – without any mess or spills.



## Rotisserie

With rotisserie, meats become more tender, juicier, and easier to baste. Whenever you need it, just put the rotisserie attachment into place.



## WiFi Connection

Samsung Built-In Oven's WiFi Connection lets you remotely monitor and control the oven using an app\* on your smartphone. From anywhere inside or outside the house, you can easily check and change settings, and adjust cooking times and temperatures.

\*Smart Home App is available on Android and iOS. A network connection is required.

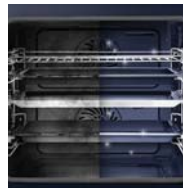

## Self Cleaning (Pyrolytic)

A Pyrolytic system keeps your oven neat and clean without any time-consuming scrubbing. It heats the oven cavity to burn off any grease and residue left from cooking, leaving only a few ashes to wipe away.



## Cleaning (Catalytic)

Imagine an oven that cleans itself while it's working. With Catalytic cleaning, the food remnant tray collects grease and residue and chemically dissolves them, so your oven is always clean.



## Cleaning (Steam)

Steam Clean helps remove even the most stubborn grime. It uses just a small amount of water inside the oven to create hot steam that loosens grease and food residue, and with Ceramic Enamel lining it's so much easier to wipe off.

# Models

## Gourmet Vapour Technology™

Gourmet Vapour Technology™ optimises the taste and texture of your food by surrounding it with vapour that quickly and evenly transfers heat and moisture, resulting in food that's deliciously crispy outside, but soft and juicy inside.

## Gourmet Vapour Technology™

Gourmet Vapour Technology™ optimises the taste and texture of your food, especially during baking or roasting. The technology creates a super-heated vapour that quickly spreads from corner to corner to ensure even cooking, even across multiple levels. So food is deliciously crispy and brown outside, but soft and juicy inside, like it's been prepared by a professional chef. And using the Vapour Level Control, you can select the vapour level that's best for each meal to maximise the taste.



### NV73J9770RS

#### Key features

- Gourmet Vapour Technology™
- Intuitive Touch TFT LCD
- WiFi Connection
- Energy Class A+
- Soft Closing Door
- 73L Capacity
- Pyrolytic Clean
- Steam Clean

#### Included accessories

- Meat Probe
- Telescopic (1 Level)
- Baking Tray (2 EA)
- Wire Rack (1 EA)
- Wire Inlay (1 EA)
- Cookbook (CD)



### NV73J7740RS

#### Key features

- Gourmet Vapour Technology™
- Intuitive Touch LED
- Energy Class A+
- Soft Closing Door
- 73L Capacity
- Catalytic Clean
- Steam Clean

#### Included accessories

- Meat Probe
- Telescopic (1 Level)
- Baking Tray (2 EA)
- Wire Rack (1 EA)
- Wire Inlay (1 EA)
- Cookbook (CD)



# Models

## Steam Twin™

Enjoy deliciously succulent and healthy steam cooked food. Real Steam Cooking locks-in moisture and vital nutrients, while Dual Cook Technology lets you cook different foods simultaneously.

## Dual Cook

Dual Cook technology gives you complete flexibility to cook multiple dishes simultaneously at different temperatures. Its upper and lower cooking zones can be used independently or together – offering flexibility, while saving time and energy. By inserting a divider, you can use one zone for smaller meals or create two independently controlled cavities to cook a variety of dishes and different size meals simultaneously, using separate temperature and time settings. And if you remove the divider you can use the whole oven for large dishes, like a holiday turkey.

### 4 in 1 ovens



### Energy saving

Its upper and lower cooking zones can be used separately to save energy.

### Time saving

It can be divided into two small ovens using a divider that enables you to save time by cooking two different dishes at once.



### BQ1VD6T131

#### Key features

- Dual Cook & Steam Cook by Steam Twin™
- Easy Water Supply & Drain System
- Powerful Steam Generator & Descaling System
- 70L Large & Useful Capacity
- Energy Class A
- Auto Cook 25 Recipes, Steam Auto Cook 25 Recipes
- Child Safety Lock
- Catalytic Clean
- Steam Clean

#### Included accessories

- Telescopic (2 Level)
- Baking Tray (2 EA)
- Wire Rack (1 EA)
- Wire Inlay (1 EA)

# Models

## Dual Cook

Dual Cook technology gives you complete flexibility. The upper and lower cooking zones can be used independently, with different temperatures and time settings. Or you can use the whole oven for large dishes.



### NV75J7570RS

#### Key features

- Dual Cook
- Intuitive & Easy LED Display
- Guide Lighting Control
- 75L Large & Useful Capacity
- Energy Class A
- Auto Cook 50 Recipes
- Soft Closing Door
- Child Safety Lock
- Pyrolytic Clean
- Steam Clean

#### Included accessories

- Telescopic (1 Level)
- Rotisserie Spit (1 EA)
- Baking Tray (2 EA)
- Wire Rack (1 EA)
- Cookbook (CD)



### NV75J5540RS

#### Key features

- Dual Cook
- Intuitive & Easy LED Display
- Guide Lighting Control
- 75L Large & Useful Capacity
- Energy Class A
- Auto Cook 50 Recipes
- Soft Closing Door
- Child Safety Lock
- Catalytic Clean
- Steam Clean

#### Included accessories

- Telescopic (1 Level)
- Baking Tray (2 EA)
- Wire Rack (1 EA)
- Cookbook (CD)



### NV75K557IRM

#### Key features

- Dual Cook
- 75L Large & Useful Capacity
- Energy Class A
- Auto Cook 50 Recipes
- Child Safety Lock
- Pyrolytic Clean
- Steam Clean

#### Included accessories

- Telescopic (1 Level)
- Baking Tray (1 EA)
- Wire Rack (2 EA)
- Cookbook (CD)

# Models

## Dual Fan

Dual Fans spin in opposite directions to spread heat evenly throughout the oven, so all of your dishes are cooked at the same temperature and speed. It also reaches its target temperature faster and is more energy efficient.



### NV70K1340BS

#### Key features

- Even Cook by Twin Fans
- Airvection
- 70L Large & Useful Capacity
- Energy Class A
- Child Safety Lock
- Catalytic Clean

#### Included accessories

- Baking Tray (1 EA)
- Wire Rack (1 EA)

# Compact Oven

Samsung Compact Ovens are small in size, but big on results. Despite their compact design they boast a 50L capacity, which is more than capable of handling multiple dishes - and even the holiday turkey! Add in their speed and abilities and they really are a great choice for a busy home.



## Features



### Speed Cooking

Speed Cooking cooks food quickly and evenly. It also features multiple heating systems, including microwaves and a fan-assisted convection that circulates heat evenly.



### Guide Lighting Control

You can control temperature and times select function easily with an intuitive step-by-step display. By following the lights it clearly shows you what to do next, based on the last option you chose, so you can prepare delicious meals without reaching for the instruction manual.



### Soft Closing Door

The Soft Closing Door smoothly and gently opens and closes with minimal noise. The door's hinge helps to slowly and safely come to a stop, giving you complete peace of mind.



### Steam Cleaning

Steam Clean helps remove even the most stubborn grime. It uses just a small amount of water inside the oven to create hot steam that loosens grease and food residue, and with Ceramic Enamel lining it's so much easier to wipe off.



### Massive 50 Litre Capacity

Massive 50 litre capacity enables you to cook much more or much larger food. You can prepare multiple dishes at once, like trays of cookies, or easily accommodate large items, like a big roast or holiday turkey.



### Dual Fans Convection

Dual Fans spin in opposite directions to spread heat evenly throughout the oven, so all of your dishes are cooked at the same temperature and speed. It also reaches its target temperature faster and is more energy efficient.



# Models

## Compact Ovens

A Samsung Compact Oven is the perfect choice when space is limited but you like to spend time cooking! With a huge 50 litre capacity and speed cooking option you simply don't need anything more.



### NQ50J9530BS

#### Key features

- MWO Combination Cooking
- Intuitive Touch TFT LCD
- 50L Large Capacity
- Pro-Roasting
- Auto Cook 35 Recipes
- Auto Defrost 5 Programmes
- Steam Clean
- Pre-stop Hinge

#### Included accessories

- Ceramic Tray (1 EA)
- Baking Tray (2 EA)
- Wire Rack (1 EA)
- Wire Tray Insert (1 EA)



### NQ50J5530BS

#### Key features

- MWO Combination Cooking
- Intuitive & Easy LED Display
- Guide Lighting Control
- 50L Large Capacity
- Pro-Roasting
- Auto Cook 20 Recipes
- Auto Defrost 5 Programmes
- Steam Clean
- Pre-stop Hinge

#### Included accessories

- Ceramic Tray (1 EA)
- Baking Tray (2 EA)
- Pure Steam Bowl



### NQ50K5130BS

#### Key features

- MWO Solo
- Pop-up Dial with Touch Buttons
- 50L Large Capacity
- Steam Clean
- Auto Cook 15 Recipes
- Auto Defrost 5 Programmes
- Child Safety Lock

#### Included accessories

- Ceramic Tray (1 EA)



### NQ50K3130BM

#### Key features

- MWO Solo
- Pop-up Dial with Touch Buttons
- 50L Large Capacity
- Steam Clean
- Auto Cook 15 Recipes
- Auto Defrost 5 Programmes
- Child Safety Lock

#### Included accessories

- Ceramic Tray (1 EA)

# Models

## Warming Drawer

Matched with selected Compact Ovens, Samsung's Warming Drawer keep food at the perfect temperature until dinner is ready.



**NL20J7100WB (matching: NQ50J9530BS, NQ50J5530BS, NQ50K5130BS)**

### Key features

- Complementary design to compact oven
- Defrosting (Temp. Ranges 30°C-80°C)
- Plate Warming
- Food Kept Warm
- Loading Weight : 20kg
- Fits a 60cm niche
- Stores accessories when not in use

# Models

## Microwave Oven

Provides a seamless look that is perfectly harmonised with modern Built-In kitchens.



**MS22M8074AT**

### Key features

- Smart Moisture Sensor
- Keep Warm
- Deodorisation
- Ceramic Enamel
- Type : Solo MWO
- 22L Capacity
- Touch (Control Type)
- Side Opening Door
- Ice Blue LED (Display)



### Smart Moisture Sensor

With the push of a button the Smart Moisture Sensor determines the interior air humidity, so the cooking mode and time can be automatically adjusted to ensure meals are always cooked perfectly.



### Keep Warm

With one touch, the Samsung microwave oven's Keep Warm function keeps food at the proper temperature without overcooking. So it stays deliciously warm and tasty, just like freshly cooked food – no matter when you serve it.



### Ceramic Enamel

The durable Ceramic Enamel is easy to keep clean and scratch-free. Its smooth surface can be cleaned without scrubbing and won't discolour over time. It's also highly rust and scratch-resistant, so it lasts longer.

# Cooktop

Samsung Induction Cooktop's modern design is complemented by a brilliant Ice blue LED display that adds an extra touch of style. It provides extremely clear and simple-to-understand information about the selected functions, making how you cook much easier to control.



# Features

## Induction Cooktop



### Magnetic Knob

A movable Magnetic Knob lets you control the power of each ring more simply and precisely. It can be completely detached, so the entire surface can be cleaned more easily.



### Flex Zone Plus

Flex Zone Plus is a large, open space on the cooktop that is specially designed for cooking multiple dishes. It is divided into 4 zones for greater flexibility and is wide and spacious enough to accommodate different sizes and shapes of cookware at once.



### Wide Flex Zone

The Wide Flex Zone is designed for cooking multiple dishes. It's wide enough to fit pots and pans of varying shapes and sizes, including large cookware.



### Easy to clean

With the Samsung Ceramic Cooktop, there's no need to worry about messy spills and splatters. Even after the greasiest cooking, the smooth, ergonomic surface will quickly wipe clean.

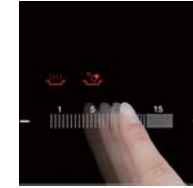

### Sliding Control

Enjoy effortless control of your cooking using the Sliding Control panel. Simply touch and glide your finger across the panel to instantly and precisely set or adjust the cooking temperature.



### Automatic Safety

Enjoy complete peace of mind with an automatic safety shut-off function that ensures that the cooktop is always off when you want it to be. It also features a child safety lock to prevent children from turning the cooktop on.



### Ice-blue Display

The modern and brilliant Ice-blue LED Display provides extremely clear information about the selected functions, so it's easier to control how you cook. It also adds an extra touch of style.



### Virtual Flame Technology™

With Virtual Flame Technology™, you can enjoy intuitive visual control and clearly see if the burner is on or off. LED lighting in front of one burner glows like a real gas flame to show how high it is turned up.



### Keep Warm

The Keep Warm button is handy for when you're preparing several dishes, as it lets you keep your food at the perfect temperature without overcooking. Your food will taste freshly prepared.

## Gas Cooktop



### Triple Crown

Cook every dish perfectly with a Triple Crown gas burner, which produces searing, instantaneous heat, so it's ideal for woks, large pans and rapid cooking like making stir fry.



### Endless Rail Grate

Even the heaviest pots and pans will slide along seamless rails, eliminating the need to lift them. Simple indicator marks also show if they're properly centred over the optimum heat. And the whole grate can be easily cleaned in a dishwasher.



### Flame Failure Safety

There's no need to worry about gas leaks, as the automatic shut-down sensor provides instant protection if any stray gas is detected.

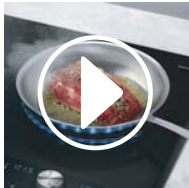

### Quick Start

The Quick Start button reduces the number of steps and time it takes to start cooking by providing high heat instantly with simply one touch. The heat can be gradually reduced, if desired.



### Pause

The Pause button provides greater convenience by allowing you to switch all cooking zones to a low power setting with just one touch. Simply touch it again to instantly return the heat to original power levels.



### Sliding Control

The extra wide and intuitive Sliding Control LED display panel enables fast and precise control of your cooking temperatures. Simply touch and glide your finger across it to instantly set or adjust the heat levels.

# Models

## Induction Cooktop

For a simple, clean and efficient way to get things done fast, look no further than a Samsung Induction Cooktop. It heats food extremely quickly and provides effortless fingertip control.



### NZ84J9770EK

#### Key features

- Virtual Flame Technology™
- Precise Control with Magnetic Knob
- 1~15 Power Level with Booster
- Wide Flex Zone
- Keep Warm
- Quick Start / Quick Stop / Pause
- 2 Stage Residual Heat Indicator
- Display Colour: Ice Blue
- 3-side Bevelled Frame
- Left 38 x 20cm 3.3 (3.6kW)
- Centre Rear 21cm 2.2 (3.2kW)
- Right Front 14.5cm 1.2 (2.0kW)
- Total Max. Power 7.0kW



### NZ84F7NC6AB

#### Key features

- Sliding Control
- 1~15 Power Level with Booster
- Flex Zone
- Keep Warm
- Quick Stop / Pause
- 2 Stage Residual Heat Indicator
- Display Colour : New Amber
- 3-side Bevelled Frame
- Left 38 x 20cm 3.3 (3.6kW)
- Centre 28cm 2.4 (3.6kW)
- Right Rear 14.5cm 1.2 (2.0kW)
- Total Max. Power 7.2kW



### NZ63J9770EK

#### Key features

- Virtual Flame Technology™
- Precise Control with Magnetic Knob
- 1~15 Power Level with Booster
- Wide Flex Zone
- Keep Warm
- Quick Start / Quick Stop / Pause
- 2 Stage Residual Heat Indicator
- Display Colour : Ice Blue
- 3-side Bevelled Frame
- Left 43 x 22cm 3.3 (3.6kW)
- Right 22cm 2.2 (3.2kW)
- Total Max. Power 6.8kW

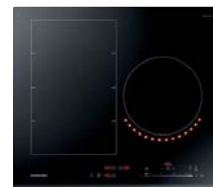

### NZ63K7777BK

#### Key features

- Virtual Flame Technology™
- Sliding Control
- 1~15 Power Level with Booster
- Flex Zone Plus
- Keep Warm
- Quick Start / Quick Stop / Pause
- 2 Stage Residual Heat Indicator
- Display Colour : New Amber
- Front Bevelled Frame
- Left 38 x 24cm 3.3 (3.6kW)
- Right 22cm 2.2 (3.2kW)
- Total Max. Power 6.8kW



### NZ64K7757BK

#### Key features

- Sliding Control
- 1~15 Power Level with Booster
- Flex Zone Plus
- Keep Warm
- Quick Start / Quick Stop / Pause
- 2 Stage Residual Heat Indicator
- Display Colour : New Amber
- Front Bevelled Frame
- Left 38 x 24cm 3.3 (3.6kW)
- Right Front 21cm 2.2 (3.2kW)
- Right Rear 14.5cm 1.4 (2.0kW)
- Total Max. Power 7.2kW



### NZ64H37070K

#### Key features

- Sliding Control
- 1~9 Power Level with Booster
- Quick Stop
- Residual Heat Indicator
- Display Colour : New Amber
- Cut Edge Frame
- Left Front 14cm 1.25 (1.5kW)
- Left Rear 22cm 2.35 (2.6kW)
- Right Front 22cm 2.35 (2.6kW)
- Right Rear 14cm 1.25 (1.5kW)
- Total Max. Power 7.2kW

# Models

## Gas Cooktop

Push back the limits of style and performance with a Samsung Gas Cooktop. Their powerful performance, effortless controllability and advanced safety features make cooking a real pleasure.

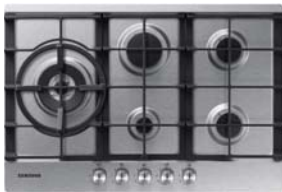

### NA75J3030AS

#### Key features

- High Power Triple Crown(3.8kW)
- 3 Cast Iron Grate & Wok Support
- Burner Types
  - 1 Triple Crown
  - 1 Rapid
  - 1 Semi-rapid
  - 1 Auxiliary
- Electronic Ignition (One Touch Ignition)
- Safety Device (Flame Failure Device)
- LNG / LPG Convergence Kit Incl.
- Fits 56cm cutout – great for an upgrade

#### Included accessories

- Wok Support



### NA64H3000AK

#### Key features

- Rapid Burner (3.0kW)
- Easy to Clean Tempered Glass Surface
- 4 Cast Iron Grate
- Burner Types
  - 1 Rapid
  - 2 Semi-rapid
  - 1 Auxiliary
- Electronic Ignition (One Touch Ignition)
- Safety Device (Flame Failure Device)
- LNG / LPG Convergence Kit Incl.



### NA64H3010AS

#### Key features

- Rapid Burner (3.3kW)
- Easy to Clean Stainless Steel Surface
- 4 Cast Iron Grate
- Burner Types
  - 2 Rapid
  - 1 Semi-rapid
  - 1 Auxiliary
- Electronic Ignition (One Touch Ignition)
- Safety Device (Flame Failure Device)
- LNG / LPG Convergence Kit Incl.

## Ceramic Cooktop

Samsung Ceramic Cooktops produce a fast and powerful radiant heating. Fingertip control and easy to clean surfaces make them effortless to use.

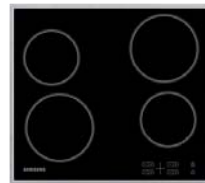

### C61RIAAMST

#### Key features

- Touch Control
- 1-15 Power Levels
- Residual Heat Indicator
- Display Colour : New Amber
- Stainless Steel Edge
- Left Front 18cm (1.8kW)
- Left Rear 14.5cm (1.2kW)
- Right Front 14.5cm (1.2kW)
- Right Rear 18cm (1.8kW)
- Total Max. Power 6kW



# Hood

Samsung Hoods bring pure convenience to your kitchen. With their high suction power and choice of speeds, they will quickly, quietly and efficiently remove steam, vapour and smoke - even if you should burn the toast. A carbon air filters also eliminates bad odours, so your kitchen always smells fresh.



## Features



### Premium Design

The premium design helps create an elegant and modern kitchen interior that is well harmonised with other kitchen appliances. Its slim profile and striking finish match the elegant and modern styling of other Samsung products to create a seamless and streamlined look.



### Washable Aluminium Filter

A durable and easy-to-maintain Aluminium Filter protects the exhaust fan and prolongs the motor life. It captures oil and dust before it clogs the motor and is really easy to clean as it's washable and small enough to fit in a dishwasher.



### LED Lights

Brilliant LED lighting makes it easy to see what you're cooking by evenly distributing light over your entire cooktop. And LED lights consume a lot less energy, last much longer, and are easier and cheaper to replace. So they save money on your monthly energy bills and the cost of replacement bulbs.



### Full Touch Display

Enjoy much simpler control with an integrated Full Touch Display. Its bright LCD panel is clear and easy to read and has the same intuitive touchscreen control as a smartphone, so you can quickly adjust settings with a gentle touch. Its stylish and exclusive look will also enhance your kitchen.

# Models

## Hood

Perfect for almost any space, a Samsung Hood is designed to keep your kitchen cleaner and fresher. They quickly remove smoke and steam, as well as any lingering odours.



**NK36M7070VS (90cm)**

**Key features**

- Stainless Steel
- Touch Control
- High Suction Power (729m<sup>3</sup>/h)
- 2 LED Lighting
- 4 Speed Extraction Modes (3 Level x 1 Booster)
- Washable Aluminium Metallic Filters
- Saturation Indicator
- Timer Function



**NK24M7070VS (60cm)**

**Key features**

- Stainless Steel
- Touch Control
- High Suction Power (729m<sup>3</sup>/h)
- 2 LED Lighting
- 4 Speed Extraction Modes (3 Level x 1 Booster)
- Washable Aluminium Metallic Filters
- Saturation Indicator
- Timer Function



**NK36M5070BM (90cm)**

**Key features**

- Black Stainless with Stylish Front Black Glass
- Touch Control
- High Suction Power (668m<sup>3</sup>/h)
- 2 LED Lighting
- 4 Speed Extraction Modes (3 Level x 1 Booster)
- Washable Aluminium Metallic Filter
- Saturation Indicator
- Timer Function



**NK24M5070BM (60cm)**

**Key features**

- Black Stainless with Stylish Front Black Glass
- Touch Control
- High Suction Power (668m<sup>3</sup>/h)
- 2 LED Lighting
- 4 Speed Extraction Modes (3 Level x 1 Booster)
- Washable Aluminium Metallic Filter
- Saturation Indicator
- Timer Function



**NK36M5070CS (90cm)**

**Key features**

- Stainless Steel Glass Construction
- Touch Control
- High Suction Power (670m<sup>3</sup>/h)
- 2 LED Lighting
- 4 Speed Extraction Modes (3 Level x 1 Booster)
- Washable Aluminium Metallic Filters
- Saturation Indicator
- Timer Function



**NK24M5070CS (60cm)**

**Key features**

- Stainless Steel Glass Construction
- Touch Control
- High Suction Power (670m<sup>3</sup>/h)
- 2 LED Lighting
- 4 Speed Extraction Modes (3 Level x 1 Booster)
- Washable Aluminium Metallic Filters
- Saturation Indicator
- Timer Function



# Models

## Hood

Perfect for almost any space, a Samsung Hood is designed to keep your kitchen cleaner and fresher. They quickly remove smoke and steam, as well as any lingering odours.



**NK24M3050PS (60cm)**

**Key features**

- Stainless Steel
- Button Control
- 512m<sup>3</sup>/h Suction Power
- Bulb Lighting Lamp
- 3 Speed Extraction Modes
- Washable Aluminium Metallic Filters



**NK24M1030IS (60cm)**

**Key features**

- Stainless Steel
- Push button controls
- 2 Bulb Lighting Lamps
- 3 Speed Extraction Modes
- Washable Aluminium Metallic Filters



REFRIGERATION

OVEN

COMPACT OVEN

INDUCTION COOKTOP

CERAMIC COOKTOP

GAS COOKTOP

HOOD

# Dishwasher

Life couldn't be easier or simpler than with a Samsung Dishwasher. Engineered with Samsung's advanced technology, it provides outstanding cleaning, as well as superior energy efficiency and low noise. And it also has a large, flexible capacity so you can simply do a half load if there's not much to wash.



## Features



### WaterWall™ Technology

Our innovative WaterWall™ dishwasher uses a revolutionary sweeping wall of jet-powered water to deliver outstanding coverage and cleaning results. Elevate your dining experience with sparkling dishes thanks to the unique cleaning power of WaterWall™ technology.



### Zone Booster™

The Zone Booster™ setting lets you wash heavily soiled pots and lightly soiled dishes at the same time with two targeted washing zones on the lower rack. Simply select a zone to automatically increase the water pressure and temperature.



### Flexible Rack

Fit items of various shapes and sizes with Flexible Rack that feature fold-down supports. Adjust the supports on the upper rack to fit cups and glasses, and the supports on the lower rack to make space for larger items like pots and pans.



### Flexible Third Rack

Our unique Third Rack is designed to accommodate all sizes and shapes of cutlery and cooking utensils. With the simple slide-in-and-out operation, you can easily fit items inside.



### Easy Height Adjustment

Tall pots, wide platters and oversized plates are no longer problems thanks to the quick and simple height adjustment of the upper rack, either up or down.



### Speed Booster

The Speed Booster setting reduces the time needed to complete the cleaning process, making it ideal for busy households and when entertaining. Get clean dishes quicker and easier no matter which cycle you use.



### Hygiene Rinsing

A hygiene button provides sanitary cleaning to minimise germs and bacteria. Its cleansing final rinse heats the water up to 70°C and maintains this temperature for several minutes, so dishes come out hygienically clean.



### One-hour Express Wash

The One-hour Express Wash option gets your dishes clean and dry much faster. It's ideal for smaller loads of lightly soiled items that don't need really intensive cleaning, such as cups, cutlery and plates, as it will put them through a complete washing and drying cycle in much less time.



### Fast 55 minute wash & dry

A Daily 55 min cycle saves you time by getting your dishes clean and dry much faster. Ideal for more lightly soiled loads that don't need a real intensive clean, such as cups and cutlery. It does a complete wash and dry in just 55 minutes.

# Models

## Fullsize Dishwasher (Fully Built-In)

If you like to keep things neat, then the Fully Built-In Samsung Dishwasher is perfect for you. It's extremely quiet despite its large capacity, so much so that you might forget it's even there.



### DW50K4050BB

#### Key features

- Full Stainless Steel Tub
- Easy Height Adjustment
- 9 Place Settings
- Energy Class A
- Energy Consumption 222 kWh per Year
- Water Consumption 2800L per Year
- 47dBA Noise Level
- 7 Programs : Intensive, Normal, Express, Eco, Delicate, Quick, Pre-wash



### DW60M5040BB

#### Key features

- Easy Height Adjustment
- Hygiene Option
- 13 Place Settings
- Energy Class A+
- Energy Consumption 295 kWh per Year
- Water Consumption 3360L per Year
- 48dBA Noise Level
- 5 Programs : Intensive, Normal, Express, Eco, Delicate



### DW60M6040BB

#### Key features

- Easy Height Adjustment
- Hygiene Option
- Full Stainless Steel Tub
- 13 Place Settings
- Energy Class A++
- Energy Consumption 262 kWh per Year
- Water Consumption 2940L per Year
- 44dBA Noise Level
- 6 Programs : Intensive, Auto, Express, Eco, Delicate, Pre-wash



### DW60M9550BB

#### Key features

- Waterwall™ Technology
- Zone Booster
- Auto Door Open
- 55 minute Daily Wash
- 14 Place Settings
- Energy Class A+++
- Energy Consumption 237 kWh per Year
- Water Consumption 2716L per Year
- 42dBA Noise Level
- 7 Programs : Intensive, Auto, Delicate, Eco, Daily (55'), Quick (38'), Self Clean

\* Coming this winter

## Models Refrigeration

### Built-In Fridge Freezers



Model Code		BRB260087WW	BRB260130WW	BRB260000WW
Energy Class		A++	A+	A+
<b>Actual Capacity</b>				
Total:		263L	267L	268L
Refrigerator:		191L	195L	196L
Freezer:		72L	72L	72L
Volt/Amps		220-240V / 50Hz	220-240V / 50Hz	220-240V / 50Hz
<b>Physical Specifications</b>				
Net Width	Width (label)	540 mm	540 mm	540 mm
Net Height	W/Hinge (label)	1,775 mm	1,775 mm	1,775 mm
	W/O hinge (label)	1,775 mm	1,775 mm	1,775 mm
Net Depth	W/Handle	550 mm	550 mm	550 mm
	W/O Handles (label)	550 mm	550 mm	550 mm
Weight		62 kg	60.5 kg	57 kg
Length of the Cable		2.5m	2.5m	2.5m
<b>Cooling Features</b>				
Cooling Technology		Twin Cooling Plus™	All Around Cooling	All Around Cooling
Cool Select Plus		Yes	No	No
Precise Cooling	(Fridge/Freezer/FleNoZone)	No / No / No	No / No / No	No / No / No
Noise		38dBA	37dBA	37dBA
Temperature Control		Digital	Digital	Digital
Metal Cooling (Duct)		Yes	No	No
Refrigerant		R600a	R600a	R600a
Freezing Capacity		9.0kg	9.0kg	9.0kg
Autonomy Hour (Temp Rising)		14hr	14hr	14hr
Smart	WiFi Dongle-Ready	Yes	N/A	N/A
<b>Fridge Features</b>				
Interior Colour		White	White	White
Shelves	Quantity	4 EA	4 EA	3 EA
	Deco	Yes	Yes	No
	Spill Proof	Yes	Yes	Yes
Take Out Tray		1 EA	No	No
Crispers	Quantity	1 EA	2 EA	1 EA
	Deco	Premium Finishing	Premium Finishing	No
Fresh Zone	Quantity	1 EA	No	No
	Deco	Premium Finishing	Premium Finishing	No
Door	Full Flushed Door	Slide Hinge	Fixed Hinge	Slide Hinge
	Reversible	Yes	Yes	Yes
	Door Alarm	Yes	Yes	Yes
Door Bins	TOTAL (ALL) Quantity	5 EA	5 EA	4 EA
	Colour	Transparent Blue	Transparent Blue	Transparent Blue
	Deco	Premium Finishing	Premium Finishing	No
Dairy Bin	Quantity	1 EA	1 EA	1 EA
	Colour	Transparent Blue	Transparent Blue	Transparent Blue
	Deco	Premium Finishing	Premium Finishing	No
Included Accessories	Wine Rack (Stainless Steel)	1 EA	1 EA	No
	Egg Container	1 EA	1 EA	1 EA
LED Lighting		Upper1EA - Pillar LED	Upper1EA - Pillar LED	Upper1EA - Pillar LED
<b>Freezer Features</b>				
Easy Open Handle™		No	No	No
Handle Type		No	No	No
Drawer	Quantity	2 EA	2 EA	2 EA
	Soft Closing	No	No	No
Shelves	Quantity	1 EA	1 EA	1 EA
	Easy Slide	Yes	Yes	Yes

## Models Refrigeration

### Freestanding Fridge Freezers



Model Code	RF56M9540SR	RF23M8080SR	RS7667FHCBC	RZ32M71207F	RR39M73407F
<b>Capacity (L)</b>					
Net Total	550	495	545	315	380
Net Freezer	199	120	184	315	-
Net Fridge	351	337	361	-	380
Net Convertible Zone	-	38	-	-	-
Gross Total	635	636	580	-	390
Gross Freezer	255	187	215	335	-
Gross Fridge	380	337	365	-	390
Net Fridge Freezer Split (%)	64/36	70/30	66/34	0/100	100/0
<b>Dimensions</b>					
Net Depth Without Handle	-	-	-	644	644
Net (W x H x D)	908 x 1825 x 733 mm	908 x 1777 x 742 mm	912 x 1789 x 712 mm	595 x 1853 x 694 mm	595 x 1853 x 694 mm
Packaging (W x H x D)	972 x 1970 x 795 mm	972 x 1922 x 795 mm	970 x 1907 x 770 mm	646 x 1950 x 760 mm	646 x 1950 x 760 mm
<b>Weight (kg)</b>					
Net/Packaging	159/170	155/166	119/123	86/93	82/89
<b>Cooling Features</b>					
Cooling Technology	Triple Cooling System/Metal Cooling	Triple Cooling System/Metal Cooling	Twin Cooling Plus	All-Around Cooling	All-Around Cooling
Multi-airflow cooling	Yes	Yes	Yes	Yes	Yes
No Frost	Yes	Yes	Yes	Yes	Yes
<b>Control Panel</b>					
Display Location	External (Left door)	Mid Drawer	External	External	External
Display Type	Colour Touch LCD screen	Digital	Blue LED	Ice Blue LED	Ice Blue LED
Fridge Temp. Control	Yes	Yes	Yes	-	Yes
Freezer Temp. Control	Yes	Yes	Yes	Yes	-
Power Freeze	Yes	Yes	Yes	Yes	-
Power Cool	Yes	Yes	-	-	-
Holiday Mode	Yes	Yes	Yes	-	Yes
Child Lock (Display)	Yes	Yes	Yes	Yes	Yes
Filter Change Indicator	Yes	Yes	Yes	-	-
<b>Refrigeration Features</b>					
No. of Drawers	2	1	2	-	2
No. of Shelves	3	5	5	-	6
Tempered Glass Shelves	Yes	Yes	Yes	-	Yes
Egg Container	Yes	Yes	Yes	-	Yes
Foldable Shelving	Yes	Yes	-	-	Yes
No. of Door Pockets	6	7	4	-	7
Water Dispenser (Non-plumbed)	-	-	-	-	Yes
LED Lighting	Yes	Yes	Yes	-	Yes
Wine Rack	-	-	-	-	Yes
Convertible Temp. Zone	Yes	Yes	-	-	-
Humidity Control Drawers	Yes	-	-	-	Yes
Metal Cooling	Yes	Yes	-	-	-
SpaceMax Technology™	Yes	-	-	-	Yes
<b>Freezer Features</b>					
Automatic Ice Maker	Yes	-	Yes	-	-
Ice Maker Position	In Fridge	-	Clearview (Indoor)	Inside of Door	-
Cubed or Crushed Ice	Yes	-	Yes	Cubed only	-
Filtered & Plumbed Water Dispenser	Yes	Yes	Yes	-	-
Water Filter Type	HAF-CIN/EXP	-	HAFEX/EXP	-	-
Freezer System	Frost Free	Frost Free	Frost Free	Frost Free	-
No. of Shelves	2	0	4	6	-
No. of Freezer Drawers	4	2	2	4	-
No. of Door Pockets	6	0	2	2	-
LED Lighting	Yes	-	Yes	Yes	-
<b>Exterior Features</b>					
Colour	Real Stainless	Real Stainless	Black	Refined Steel	Refined Steel
Reversible Doors	-	-	-	Yes	Yes
Handle Type	Recessed	Recessed	Easy Open	Bar	Bar
<b>Other Information</b>					
Warranty (yrs)	5 (by redemption)	5 (by redemption)	2 years	5 (by redemption)	5 (by redemption)
Door Alarm	Yes	Yes	Yes	Yes	Yes
Freezer Star Rating	4 Star	4 Star	4 Star	4 star	N/A
Energy Grade	A+	A+	A+	A+	A+
Climate Class	SN, N, ST, T	SN, N, ST, T	SN, N, ST, T	SN-T	SN-T
Ambient Operating Temp.	10°C - 43°C	10°C - 43°C	10°C - 43°C	10°C - 43°C	10°C - 43°C
Freezing Capacity (kg/24hr)	12	7	12	21	N/A
Temperature Rise Time (hr)	14	14	12	12	N/A
Noise Level (dB)	40	40	39	41	41
Energy Consumption (kWh/annum)	460	419	450	277	146
Refrigerant	R600a	R600a	R600-a	R600a	R600a
<b>Controllable Temp./Special compartment</b>					
Suitable for (food types)	All, frozen and chilled foods	All, frozen and chilled foods	-	-	-
Temperature range	-23/-17/-1/2°C	-1/1/3/5°C	-	-	-
Capacity (L)	100	38	-	-	-
Clear Front	No	No	-	-	-
Special features	Can be Fridge or freezer	Can be Fridge or freezer	-	-	-
Control features	Choose between 4 temperatures	Choose between 4 temperatures	-	-	-
<b>Further Information</b>					
HFC Free	External	Yes	External	Yes	Yes
CFC Free	External	Yes	Yes	Yes	Yes
Suitable for outbuildings	No	No	No	No	No
Special features	21.5 inch HD screen	-	-	-	-
Door hinge (Left, Right, Reversible)	Left and Right	Left and Right	Left and Right	Reversible	Right Reversible

## Models Vapour/Steam Twin™



Model Code	NV73J9770RS	NV73J7740RS	BQ1VD6T131	
<b>Oven Features</b>				
Energy Class	A+	A+	A	
Cavity Wall	Flat / Side Racks	Flat / Side Racks	Flat / Side Racks	
Oven Colours	Stainless Steel	Stainless Steel	Stainless Steel	
Door	Glass panes Opening Soft Closing Door	Triple Drop Down Soft Close	Triple Drop Down No	
Interior Lamp (W)	40W (Halogen)	40W (Halogen)	25W / 40W (Bulb / Halogen)	
Interior Lights (Position)	Top	Top	Rear / Side	
Control	Control Panel Height Display Control Method WiFi	85mm 4.6" Touch LCD LED / Ice Blue Full Touch	115mm LED / Blue Pop-up Dial	
Cleaning Method	Pyrolytic Catalytic Steam Grill Heater	Pyrolytic No Yes (Back Wall) Steam Cleaning Swing	No Yes (Back Wall) Yes (Back Wall) Steam Cleaning Swing	
<b>Electric Features</b>				
Temp Ranges	Single Convection Single Grill Upper or Lower Twin	30~275°C 100~300°C No No	40~250°C 40~270°C 40~250°C 170~250°C	
Upper Grill (Small / Large)	1600W / 1100W	1600W / 1100W	1600W / 1100W	
Bottom Heater	1100W	1100W	1100W	
Convection (Upper / Lower)	1800W	1800W	1200W / 1200W	
Input Power	3500~3850W	3500~3850W	3650W	
Over Voltage Protection	Yes	Yes	No	
<b>Cooking Modes</b>				
Single Mode	Oven Modes Conventional Convection Eco Convection Large Grill Eco Grill Fan Grill Bottom Heat + Convection Top Heat + Convection Bottom Heat Intensive Cook Pro-roasting Special Function Vapour + Convection Vapour Top Heat + Convection Vapour Bottom Heat + Convection Steam Cook Steam Assist Keep Warm Plate Warm Defrost Prove Dough Slow Cook Drying Auto Cook Recipes Favourite (=Memory Cook)	30~275°C 30~275°C 30~275°C 100~300°C 100~300°C 100~275°C 40~275°C 40~275°C 100~230°C 40~275°C No 80~200°C 120~275°C 120~275°C 120~275°C No No 40~100°C 30~80°C No No No 70~120°C 40~90°C 80 EA 10 EA	30~275°C 30~275°C 30~275°C 100~300°C 100~300°C No 40~275°C 40~275°C No No 80~200°C 120~275°C 120~275°C 120~275°C No No 40~100°C 30~80°C No No No No No 40 EA No	40~250°C 40~250°C No 40~270°C 40~270°C No 40~250°C 40~250°C No No No No No No No 130~250°C No No No No No 50 EA No
Upper Mode	Convection Top Heat + Convection Large Grill	No No No	40~250°C 40~250°C 40~250°C	
Lower Mode	Convection Bottom Heat Bottom Heat + Convection Steam Cook Steam Assist	No No No No No	40~250°C No 40~250°C 1 / 2 / 3 130~250°C	
Twin Mode	(Upper) Mode x (Lower) Mode	No	3 Mode x 3 Mode = 9 EA	
<b>Control Features</b>				
Clock	Yes	Yes	Yes	
Child Safety Lock	Yes	Yes	Yes	
Count Timer	Yes	Yes	Yes	
Cook Time	Yes	Yes	Yes	
End Time	Yes	Yes	Yes	
Language Option	11 EA	No	No	
Sound	Yes	Yes	Yes	
<b>Equipment Supplied</b>				
Accessory	Telescopic Tray Rack No Rotisserie Spit Meat Probe Cookbook (CD)	1 Level 2 EA Wire Rack 1 EA, Wire Inlay 1 EA No Meat Probe Yes	2 Level 2 EA Wire Rack 1 EA, Wire Inlay 1 EA No No No No	
<b>Application Dimensions</b>				
Dimension (W x H x D)	Outside Cutout Shipping	595 x 595 x 566 560 x 572 x 545 682 x 645.5 x 656	595 x 595 x 566 560 x 572 x 545 682 x 645.5 x 656	
Capacity	Net Volume Net Volume (Upper or Lower)	73L No	70L 30 / 32L	
Weight	Gross Net	48.6 45.9	47.2 44.2	

## Models Dual Cook/Dual Fan



Model Code	NV75J7570RS	NV75J5540RS	NV75K5571RM	NV70K1340BS	
<b>Oven Features</b>					
Energy Class	A	A	A	A	
Cavity Wall	Flat / Side Racks	Flat / Side Racks	Flat / Side Racks	Flat / Side Racks	
Oven Colours	Stainless Steel	Stainless Steel	Black Stainless Steel	Stainless Steel	
Door	Glass panes Opening Soft Closing Door	Triple Drop Down Soft Close	Triple Drop Down Soft Close	Triple Drop Down No	
Interior Lamp (W)	40W / 40W (Halogen)	40W / 40W (Halogen)	40W / 40W (Halogen)	25W (Halogen)	
Interior Lights (Position)	Top / Side	Top / Side	Top / Side	Side	
Control	Control Panel Height Display Control Method WiFi	85mm LED / Ice Blue Pop-up Dial (with Touch Buttons)	85mm LED / Ice Blue Pop-up Dial (with Touch Buttons)	115mm LED / Ice Blue Non Pop-up Dial	
Cleaning Method	Pyrolytic Catalytic Steam Grill Heater	Pyrolytic No Yes (Back Wall) Steam Cleaning Swing	Pyrolytic No Yes (Back Wall) Steam Cleaning Swing	No Yes (Back Wall) No Steam Cleaning Fixed	
<b>Electric Features</b>					
Temp Ranges	Single Convection Single Grill Upper or Lower Twin	30~275°C 100~300°C 40~250°C 40~250°C	30~275°C 100~300°C 40~250°C 40~250°C	30~250°C 100~270°C 40~250°C 40~250°C	
Upper Grill (Small / Large)	1600W / 1100W	1600W / 1100W	1600W / 1100W	1600W / 700W	
Bottom Heater	1100W	1100W	1100W	600W	
Convection (Upper / Lower)	1200W / 1200W	1200W / 1200W	1200W / 1200W	1700W	
Input Power	3650~3950W	3650~3950W	3650~3950W	3400~3600W	
Over Voltage Protection	Yes	Yes	Yes	No	
<b>Cooking Modes</b>					
Single Mode	Oven Modes Conventional Convection Eco Convection Large Grill Eco Grill Fan Grill Bottom Heat + Convection Top Heat + Convection Bottom Heat Intensive Cook Pro-roasting Special Function Vapour + Convection Vapour Top Heat + Convection Vapour Bottom Heat + Convection Steam Cook Steam Assist Keep Warm Plate Warm Defrost Prove Dough Slow Cook Drying Auto Cook Recipes Favourite (=Memory Cook)	30~275°C 30~275°C 30~275°C 100~300°C 100~300°C No 40~275°C 40~275°C 100~230°C No 80~200°C No No No No No 40~100°C 30~80°C No No No No No 40 EA (Twin Mode 10 EA) No	30~275°C 30~275°C 30~275°C 100~300°C 100~300°C No 40~275°C 40~275°C 100~230°C No 80~200°C No No No No No 40~100°C 30~80°C No No No No No 40 EA (Twin Mode 10 EA) No	30~250°C 30~250°C 30~250°C 100~270°C 100~270°C No 40~250°C 40~250°C 100~230°C No 80~200°C No No No No No 40~100°C 30~80°C No No No No No 40 EA (Twin Mode 10 EA) No	50~250°C 50~250°C No 1 / 2 / 3 No No No 50~250°C 50~250°C No No No No No No No No No No No No No No No No No No No
Upper Mode	Convection Top Heat + Convection Large Grill	40~250°C 40~250°C 200~250°C	40~250°C 40~250°C 200~250°C	40~250°C 40~250°C 200~250°C	
Lower Mode	Convection Bottom Heat Bottom Heat + Convection Steam Cook Steam Assist	40~250°C No 40~250°C No No	40~250°C No 40~250°C No No	40~250°C No 40~250°C No No	
Twin Mode	(Upper) Mode x (Lower) Mode	3 Mode x 3 Mode = 9 EA	3 Mode x 3 Mode = 9 EA	3 Mode x 3 Mode = 9 EA	
<b>Control Features</b>					
Clock	Yes	Yes	Yes	Yes	
Child Safety Lock	Yes	Yes	Yes	Yes	
Count Timer	Yes	Yes	Yes	Yes	
Cook Time	Yes	Yes	Yes	Yes	
End Time	Yes	Yes	Yes	No	
Language Option	No	No	No	No	
Sound	Yes	Yes	Yes	Yes	
<b>Equipment Supplied</b>					
Accessory	Telescopic Tray Rack No Rotisserie Spit Meat Probe Cookbook (CD)	1 Level 2 EA Wire Rack 1 EA No Meat Probe Yes	1 Level 2 EA Wire Rack 1 EA No No No Yes	No 1 EA Wire Rack 1 EA No No No Yes	
<b>Application Dimensions</b>					
Dimension (W x H x D)	Outside Cutout Shipping	595 x 595 x 566 560 x 572 x 545 682 x 645.5 x 656	595 x 595 x 566 560 x 572 x 545 682 x 645.5 x 656	595 x 595 x 566 560 x 572 x 545 682 x 645.5 x 656	
Capacity	Net Volume Net Volume (Upper or Lower)	75L 34 / 32L	75L 34 / 32L	75L 35 / 32L	
Weight	Gross Net	50.0 47.2	45.8 41.3	50.0 47.2	

## Models Compact Oven



Model Code	NQ50J9530BS	NQ50J5530BS	NQ50K5130BS	NQ50K3130BM
<b>Oven Features</b>				
Type	Combi MWO	Combi MWO	MWO Solo	MWO Solo
Cavity Material	Ceramic Enamel	Ceramic Enamel	Ceramic Enamel	Ceramic Enamel
Oven Color (Con-panel / Door)	Stainless Steel	Stainless Steel	Stainless Steel	Black Stainless Steel (Matt Black)
Door	Glass	Triple	Triple	Triple
	Opening	Drop Down	Drop Down	Drop Down
	Handle Color	Stainless Steel	Stainless Steel	Stainless Steel
	Prestop Hinge	Yes	Yes	No
Interior Lamp (Watts)	40W (Halogen)	40W (Halogen)	1 x 25W (Wide)	1 x 25W (Wide)
Interior Lights	Left (Side)	Left (Side)	Left (Side)	Left (Side)
Control	Control Panel Height	85 mm	85 mm	85 mm
	Display	4.6" Touch LCD	LED / Ice Blue	LED / Ice Blue
	Control Method	Touch LCD	Pop-up Dial (with Touch Buttons)	Pop-up Dial (with Touch Buttons)
Cleaning Method	Steam	Yes	Yes	Yes
	Grill Heater	Fixed	Fixed	No
<b>Electric Features</b>				
MWO Watts	900 W	800 W	900 W	900 W
Oven Temp Ranges	Convection : 40~250°C	Convection : 40~230°C	No	No
	Grill : 150~250°C	Grill : 150~230°C	No	No
Upper Grill (In / Out)	1400W / 1100W	1400W / 1100W	No	No
Lower Grill	1000W	1000W	No	No
Convection (Upper / Lower)	1000W	No	No	No
Fan	2	1	No	No
Input Power	3200W	3000W	1650W	1650W
<b>Cooking Modes</b>				
MWO Mode	MWO	Yes	Yes	Yes
	Auto Defrost	Yes (5 EA)	Yes (5 EA)	Yes
	Auto Reheat	No	No	Yes
	Keep Warm (MWO)	No	No	Yes
	Power Level (MWO)	100/180/300/450/600/750/900	100/180/300/450/600/700/800	100/180/300/450/600/750/900
Combi-MWO Mode	MWO + Grill	Yes	No	No
(MWO + Oven)	MWO + Convection	Yes	Yes	No
	MWO + Roast	Yes	No	No
Oven Mode	Steam Generator	No	No	No
	Steam + Convection	No	No	No
	Steam + Reheat	No	No	No
	Convection	Yes	Yes	No
	Roasting (Convection + Top)	Yes	No	No
	Heat	Yes	No	No
	Conventional	Yes	Yes	No
	Grill	Yes	No	No
	Fan Grill	Yes	No	No
	Pizza (Convection + Bottom)	Yes	No	No
	Intensive (Top + Bottom + Convection)	Yes	No	No
	Vegetable Function	No	Yes	No
	Multi-level Cook Mode	Yes	No	No
	Keep Warm Mode	Yes	Yes	No
	Deodorization	No	No	Yes
	Auto Cook Recipes	40 EA (Auto Cook 31 EA, Speed Cook 4 EA, Auto Defrost 5 EA)	25 EA (Auto Cook 10 EA, Auto Defrost 5 EA, Vegetable 10 EA)	20 EA (Auto Cook 15 EA, Auto Defrost 5 EA)
<b>Control Features</b>				
	Clock	Yes	Yes	Yes
	Child Safety Lock	Yes	Yes	Yes
	Cook Time	Yes	Yes	No
	End Timer	Yes	Yes	No
	Oven Temp	Yes	Yes	No
	Sound	Buzzer	Buzzer	Buzzer
	Sound On / Off (Hidden)	Yes	Yes	No
	Demo Mode	Yes (Hidden)	Yes (Hidden)	Yes (Hidden)
<b>Equipment Supplied</b>				
Accessory	Ceramic Tray	1 EA	1 EA	1 EA
	Baking Tray	2 EA	1 EA	No
	Wire Rack	1 EA	No	No
	Wire Tray Insert	1 EA	1 EA	No
	Steam Tray	No	1 EA (Pure Steam Bowl)	No
<b>Application Dimensions</b>				
Dimension (W x H x D)	Outside	595 x 454.2 x 570	595 x 454.2 x 570	595 x 454.2 x 570
	Cutout	555 x 445 x 548.8	555 x 445 x 548.8	555 x 445 x 548.8
	Shipping	700 x 578 x 663	700 x 578 x 663	700 x 578 x 663
Capacity	Usable Capacity	50 L	50 L	50 L

## Models Warming Drawer



Model Code	NL20J7100WB
<b>Design</b>	
Design	Glass/Stainless Steel Frame
<b>Features</b>	
Size	600 x 150
Cut-out	560 x 550 x 150
Handle	Push & Pull Door
Rail	Telescopic Rail
Weight Capacity	25kg
	Mechanic Knob
Temp Range	30~80°C
Energy Consumption	420W
Safe Opening & Closing	Anti-slip Mat
Control	LED Status Lamp
Dimension	595 x 545 x 140
Remark	Push-pull Tolerance : 21mm Door Gap Between Compact and Warmer : 8mm

## Models Microwave Oven



Model Code	MS22M8074AT
<b>General</b>	
Capacity	0.7 cu.ft. / 22 Litre
Type	Installation
	Heat Source
Power	Power Source
	Output Power (Microwave)
	Output Power (Grill)
	Output Power (Convection)
	Power Consumption
	Max Output Power
Display	Type
	Language Option
Sensor	Yes (Moisture)
Control Method	Touch
Door Open Mechanism	Push button
MW Distribution Mechanism	Turntable
<b>Features</b>	
Keep Warm (Food)	Yes
Power Level	6
Time Control	Touch (+, -)
Weight / Serving Control	Touch (+, -)
One Minute / 30 secs Plus	30 secs Plus
Turntable on / off	No
Defrost (Auto / Power / Sensor)	Yes
Auto Reheat/cook	Yes
Auto Crusty cook	No
Auto Power Steam cook	No
Sensor Cook	Yes
Child Lock	Yes
<b>Materials &amp; Finishes</b>	
Cabinet Colour	Black
Door Colour	Black
Cavity Interior	Ceramic Enamel
Turntable	Material
	Size
Grill Heater	N/A
<b>Accessory</b>	
Grill Rack	N/A
Crusty Plate	N/A
<b>Physical Specification</b>	
Dimension (W x H x D)	Cavity
	Outside
	Shipping
Weight (Kg)	Weight (Net)
	Weight (Shipping)

## Models Induction Cooktop



Model Code		NZ84J9770EK	NZ63J9770EK	NZ63K7777BK	NZ64K7757BK
<b>Dimensions (W x D x H)</b>					
	Outside (Max.)	800 x 520 x 56	600 x 520 x 56	600 x 520 x 56	600 x 520 x 56
	Packing	902 x 594 x 139	712 x 594 x 142	712 x 594 x 142	712 x 594 x 142
	Cut-out Size	750 x 490	560 x 490	560 x 490	560 x 490
<b>Features</b>					
Surface	Frame	3 Bevel	3 Bevel	1 Bevel	1 Bevel
Display	Control Method	Magnetic Knob	Magnetic Knob	Common Control	Common Control
	Type	Integrated Knob Dial	Integrated Knob Dial	Sliding & DirectAccess	Sliding & DirectAccess
	LED Colour	Ice Blue	Ice Blue	New Amber	New Amber
	LED Indicator	No	No	No	No
Power	140mm	No	No	No	No
	145mm	No	No	No	1.4 / 2.0K(B)
	160mm	1.2 / 2.0K(B)	No	No	No
	180mm	No	No	No	No
	210mm	No	No	No	2.2 / 3.2K(B)
	220mm	2.2 / 3.2K(B)	2.2 / 3.2K(B)	2.2 / 3.2K(B)	No
	280mm	No	No	No	No
	Flex Zone (Front)	1.8 / 2.6K(B)	1.8 / 2.6K(B)	1.8 / 2.6K(B)	1.8 / 2.6K(B)
	Flex Zone (Centre)	No	No	1.8 / 3.0K(B)	1.8 / 3.0K(B)
	Flex Zone (Rear)	1.8 / 2.6K(B)	1.8 / 2.6K(B)	1.8 / 2.6K(B)	1.8 / 2.6K(B)
	Flex Zone TOT	3.3 / 3.6K(B)	3.3 / 3.6K(B)	3.3 / 3.6K(B)	3.3 / 3.6K(B)
	Total Power	7.0kW	6.8kW	6.8kW	7.2kW
	Q'ty of Booster	4	3	3	4
Safety Function	Residual Heat Indicator	2 Stage	2 Stage	2 Stage	2 Stage
	Small Utensil Detection	Yes	Yes	Yes	Yes
	Auto Pan Detection	Yes	Yes	Yes	Yes
	Safety Shutoff	Yes	Yes	Yes	Yes
	Child Safety Lock	Yes	Yes	Yes	Yes
	High Temp Limit	Yes	Yes	Yes	Yes
Control Feature	Sound On / Off Hidden Lock	Yes	Yes	Yes	Yes
	Power Level	15 + Booster	15 + Booster	15 + Booster	15 + Booster
	Timer	99min	99min	99min	99min
	Power Control	Yes	Yes	Yes	Yes
	Direct Access	Yes	Yes	Yes	Yes
	Power On / Off	Yes	Yes	Yes	Yes
	Pan Grilling	No	No	No	No
	Pause	Yes	Yes	Yes	Yes
	Quick Start	Yes	Yes	Yes	Yes
	Demo Mode	Yes	Yes	Yes	Yes
	Quick Stop	Yes	Yes	Yes	Yes
	Keep Warm	Yes	Yes	Yes	Yes
	Up Timer	Yes	Yes	Yes	Yes
	Down Timer	Yes	Yes	Yes	Yes
Energy Eff.	Stand By Power Consumption	Under 0.5W	Under 0.5W	Under 0.5W	Under 0.5W
Noise	Noise Level (Operating)	Under 43dB	Under 43dB	Under 43dB	Under 43dB
Power Cable	Power Cable Type	5 Wire	5 Wire	5 Wire	5 Wire
Weight	Net / Gross	16.5Kg / 19.5Kg	13.4Kg / 15.9Kg	12.8Kg / 15.6Kg	13.2Kg / 16.0Kg
Dimension	Flex Size	225 x 435mm	225 x 435mm	240 x 380mm	240 x 380mm

## Models Induction/Ceramic Cooktop



Model Code		NZ64H37070K	C61R1AAMST
<b>Dimensions (W x D x H)</b>			
	Outside (Max.)	590 x 520 x 57	575 x 505 x 20
	Packing	690 x 645 x 115	683 x 593 x 172
	Cut-out Size	560 x 490	560 x 490
<b>Features</b>			
Surface	Frame	Cut Edge	4 Stainless Steel
Display	Control Method	Common Control	Common Control
	Type	Sliding	Touch
	LED Colour	New Amber	New Amber
	LED Indicator	No	No
Power	140mm	1.25 / 1.5K(B) x 2	No
	145mm	No	1.2kw x2
	160mm	No	No
	180mm	No	1.8kw x2
	210mm	No	No
	220mm	2.35 / 2.6K(B) x 2	No
	280mm	No	No
	Flex Zone (Front)	No	No
	Flex Zone (Centre)	No	No
	Flex Zone (Rear)	No	No
	Flex Zone TOT	No	No
	Total Power	7.2kW	6 kw
	Q'ty of Booster	4	No
Safety Function	Residual Heat Indicator	1 Stage	Yes
	Small Utensil Detection	Yes	No
	Auto Pan Detection	Yes	No
	Safety Shutoff	Yes	Yes
	Child Safety Lock	Yes	Yes
	High Temp Limit	Yes	No
Control Feature	Sound On / Off Hidden Lock	No	No
	Power Level	9 + Booster	TBC
	Timer	99min	No
	Power Control	Yes	Yes
	Direct Access	Boost Level Only	No
	Power On / Off	Yes	Yes
	Pan Grilling	No	No
	Pause	No	No
	Quick Start	No	No
	Demo Mode	No	No
	Quick Stop	Yes	No
	Keep Warm	No	No
	Up Timer	No	No
	Down Timer	Yes	No
Energy Eff.	Stand By Power Consumption	Under 0.5W	Under 0.5W
Noise	Noise Level (Operating)	Under 43dB	Under 43dB
Power Cable	Power Cable Type	5 Wire	5 Wire
Weight	Net / Gross	10.5Kg / 12.0Kg	7.5kg/9.5kg
Dimension	Flex Size	No	No

## Models Gas Cooktop



Model Code	NA75J3030AS	NA64H3000AK	NA64H3010AS
<b>Mains Specifications</b>	Square	Square	Square
Width (cm)	75	60	60
Gas Cooking Zones	5	4	4
Colour	Stainless Steel	Black Tempered Glass	Stainless Steel
Pan Supports	Cast-iron (Wok Pan support Included)	Cast-iron	Cast-iron
Wok Grate	Wok	No	No
Knob Design	Neo	Neo	Neo
<b>Burner Features</b>			
Gas	Triple Crown	No	No
	Rapid	3.0kW x 1	3.3kW x 2
	Semi-rapid	2.0kW x 1	2.0kW x 1
	Auxiliary	1.0kW x 1	1.0kW x 1
	Total	11.8kW	9.6kW
<b>Safety Functions</b>			
Flame Failure Device	Yes	Yes	Yes
<b>Convenience</b>			
One Hand Ignition	Yes	Yes	Yes
<b>Installation/Connection</b>			
Gas Power Consumption (W)	1.0W	1.0W	1.0W
Power Cord without Plug	Yes	Yes	Yes
Power Supply	220-240V, 50 / 60Hz	220-240V, 50 / 60Hz	220-240V, 50 / 60Hz
Delivery Status	Natural Gas	Natural Gas	Natural Gas
Additional Injectors	LPG Conversion Injectors Included	LPG Conversion Injectors Included	LPG Conversion Injectors Included
<b>Dimensions/Weight</b>			
Net Weight (kg)	15.6 (Include Wok)	14.8	10.6
Cut-out Size (W x L mm)	560 x 490	560 x 490	560 x 490
Net Dimension (W x D x H mm)	750 x 510 x 98	600 x 520 x 99	600 x 510 x 90

## Models Hood



Model Code	NK36M7070VS	NK24M7070VS	NK36M5070BM	NK24M5070BM
Type	Head Free (Inox)	Head Free (Inox)	Box (Black Glass, Black Stainless Steel Matt)	Box (Black Glass, Black Stainless Steel Matt)
<b>Mains Specifications</b>				
References	Stainless Steel A430	Stainless Steel A430	Matt Black + Black Glass	Matt Black + Black Glass
Size (cm)	90	60	90	60
Model Type Install	Wall-mount	Wall-mount	Wall-mount	Wall-mount
<b>Technical Specifications</b>				
Type of Controls	Touch Control	Touch Control	Touch Control	Touch Control
Energy Class	B	B	B	B
Display Colour	Ice Blue	Ice Blue	Ice Blue	Ice Blue
Extraction Type	Ducting or Recirculating	Ducting or Recirculating	Ducting or Recirculating	Ducting or Recirculating
Number of Motors / Fans	1 / 1	1 / 1	1 / 1	1 / 1
Number of Extraction Speeds	4 (3 + Booster)	4 (3 + Booster)	4 (3 + Booster)	4 (3 + Booster)
Max Extraction (m3/hr)	585	585	531	531
Boost Extraction (m3/hr)	729	729	668	668
Max Sound Power (dBA)	68	68	70	70
Boost Sound Power (dBA)	73	73	75	75
Lighting	2 x 2.5W LED	2 x 2.5W LED	2 x 2.5W LED	2 x 2.5W LED
Number of Metallic Filter (Aluminium)	2	1	3	2
Total power of Connection (W)	265	265	265	265
Ducting Diameter (mm)	150	150	150	150
Saturation Filter Indicator	Yes	Yes	Yes	Yes
Timer	Yes	Yes	Yes	Yes
Booster	Yes	Yes	Yes	Yes
Air Diverter	Yes	Yes	Yes	Yes
Charcoal Filter	No	No	No	No
<b>Accessories (Optional)</b>				
Charcoal Filter Reference	DG81-02279A	DG81-02279A	DG81-02294A	DG81-02294A
<b>Dimensions</b>				
Gross Weight	30.8	24.5	20	16.3
Net Weight	23.3	19.2	17	13.9
Gross Dimensions (W x D x H)	1034 x 915 x 433	759 x 915 x 433	945 x 375 x 575	645 x 375 x 575
Net Dimensions (W x D x H)	Min. 1,040~ Max. 1,440 x 898 x 137	Min. 1,040~ Max. 1,440 x 598 x 137	Min. 619~ Max. 1,147 x 900 x 500	Min. 619~ Max. 1,147 x 600 x 500

\*To be installed for recirculation all models require a a carbon filter which needs to be purchased separately.



## Models Hood



Model Code	NK36M5070CS	NK24M5070CS	NK24M3050PS	NK24M1030IS
Type	Box (Curved)	Box (Curved)	Pyramid	Pyramid
<b>Mains Specifications</b>				
References	Stainless Steel A430	Stainless Steel A430	Stainless Steel A430	Stainless Steel A430
Size (cm)	90	60	60	60
Model Type Install	Wall-mount	Wall-mount	Wall-mount	Intergrated
<b>Technical Specifications</b>				
Type of Controls	Touch Control	Touch Control	Push Button	Button
Energy Class	B	B	D	N/A
Display Colour	Ice Blue	Ice Blue	No	N/A
Extraction Type	Ducting or Recirculating	Ducting or Recirculating	Ducting or Recirculating	Ducting or Recirculating
Number of Motors / Fans	1/1	1/1	1/1	1/1
Number of Extraction Speeds	4 (3 + Booster)	4 (3 + Booster)	3	3
Max Extraction (m3/hr)	558	558	512	384
Boost Extraction (m3/hr)	670	670	No	N/A
Max Sound Power (dBA)	69	69	70	70
Boost Sound Power (dBA)	73	73	No	N/A
Lighting	2 x 2.5W LED	2 x 2.5W LED	2x28W Bulbs	2x LED 3W
Number of Metallic Filter (Aluminium)	1	1	3	2
Total power of Connection (W)	255	255	236	136
Ducting Diameter (mm)	150	150	150	120
Saturation Filter Indicator	Yes	Yes	No	No
Timer	Yes	Yes	No	No
Booster	Yes	Yes	No	No
Air Diverter	Yes	Yes	Yes	No
Charcoal Filter	No	No	No	No
<b>Accessories (Optional)</b>				
Charcoal Filter Reference	DG81-02294A	DG81-02294A	DG81-02329A	CFC0038000
<b>Dimensions</b>				
Gross Weight	17.3	16	10.2	7.5
Net Weight	14.5	13.3	8	6
Gross Dimensions (W x D x H)	945 x 415 x 575	645 x 375 x 575	940 x 263 x 510	354 x 241 x 634
Net Dimensions (W x D x H)	Min. 603~ Max. 1,130 x 900 x 450	Min. 603~ Max. 1,130 x 600 x 450	Min. 739~ Max. 1,061 x 900 x 450	600 x 280 x 180

\*To be installed for recirculation all models require a a carbon filter which needs to be purchased separately.

## Models Fullsize Dishwasher Fully Built-In



Model Code	DW50K4050BB	DW60M5040BB	DW60M6040BB	DW60M9550BB
Project Name	DW4500K	DW5000M	DW5500M	DW9000M
<b>Design</b>				
Control Type	Hidden Touch	Hidden Touch	Hidden Touch	Hidden Touch
Colour	N/A	N/A	N/A	N/A
<b>Performance</b>				
Capacity (Place Setting)	9	13	13	14
Energy Class	A	A+	A++	A+++
Cycle Consumption	0.78	1.03 kWh/cycle	0.92 kWh/cycle	237 kWh/year
Annual Consumption	222	295 kWh/year	262 kWh/year	0.833 kWh/cycle
Wash Performance	A	A	A	A
Drying Performance	A	A	A	A
Water Consumption per Cycle	10L	12L	10.5L	9.7L
Annual	2800	3360	2940	2716
Noise Level (dBA)	47	48	44	42
<b>Function</b>				
Programs	Number of Programs	7	5	6
	Intensive	Yes	Yes	Yes
	Auto	No	No	Yes
	Delicate	Yes	Yes	Yes
	Eco	Yes	Yes	Yes
	Daily 55' (Express)	No	No	Yes
	Quick	Yes	No	Yes
	Self Clean	No	No	Yes
	Normal	Yes	Yes	No
	Express	Yes	Yes	No
	Pre Wash	Yes	No	No
Options	Delay Start	Yes	Yes	Yes
	Half Load	Yes	Yes	Yes
	Speed Booster	No	No	Yes
	Sanitise	No	Yes	Yes
	Child Lock	Yes	Yes	Yes
	Zone Booster	No	No	No
	Dry Plus	No	No	Yes
Auto Open	Auto Door Open	No	No	Yes
Safety	Aqua Stop	Yes	Yes	Yes
<b>InnerSystem</b>				
Upper	Basket Handle	No	No	Yes (Plastic)
	Adjustable Height	Yes	Yes (Auto)	Yes
	Fold Down Supports	No	Yes	No
Lower	Basket Handle	No	No	Yes (Plastic)
	Fold Down Supports	Yes	Yes	Yes
Cutlery	Cutlery Tray	No	No	Yes
	Cutlery Basket	Yes	Yes	No
<b>Dimensions</b>				
Net	Net Width	448	596	598
	Net Height	815	805	815
	Net Depth	558	558	550
	Net Weight	31	37.5	43
Gross	Gross Width	510	656	655
	Gross Height	885	885	871
	Gross Depth	675	675	645
	Gross Weight	36	43	50
<b>Installation</b>				
Electrical (Volts / Hertz / Amps)		220-240V / 50Hz	220-240V / 50Hz	220-240V/50Hz/10A
Heater Watts	1800W	1800-2000W	1760-2100W	2000-2300W
Circulation Motor	50W	60 to 100W	85W	60 to 100W
Drain Pump	30W	30W	30W	30W
Levelling Screws	0 to 50mm	0 to 90mm	0 to 30mm	60mm

# Models/Refrigeration INSTALLATION GUIDE

BRB260130WW

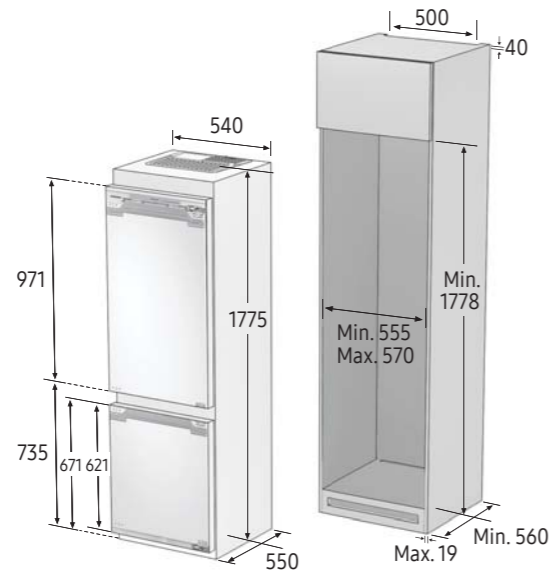

BRB260087WW, BRB260000WW

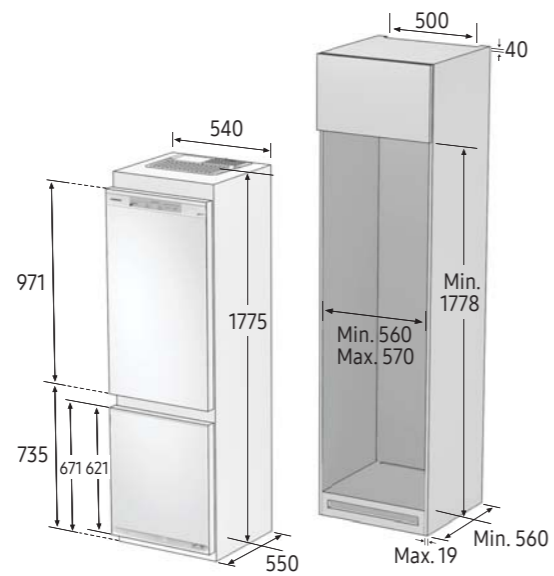

# Models/Refrigeration INSTALLATION GUIDE

RF56M9540SR, RF23M8080SR, RS7667FHCBC

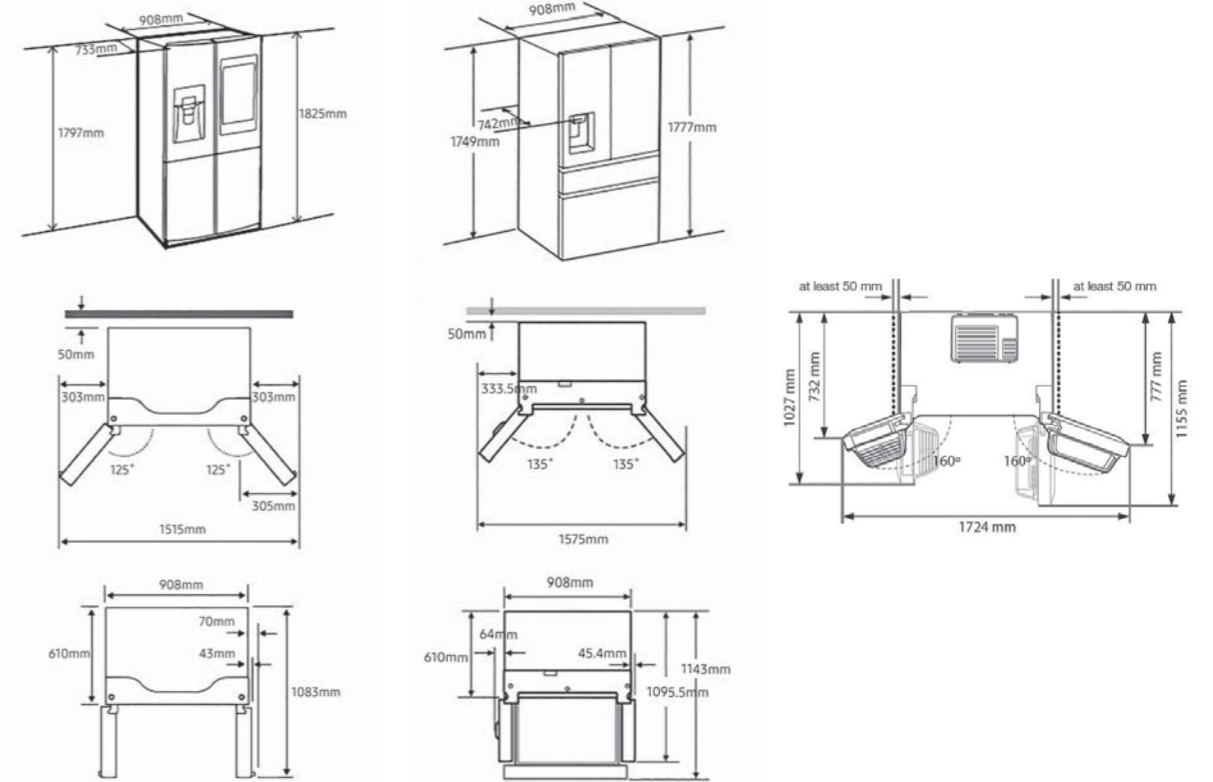

RZ32M71207F, RR39M73407F

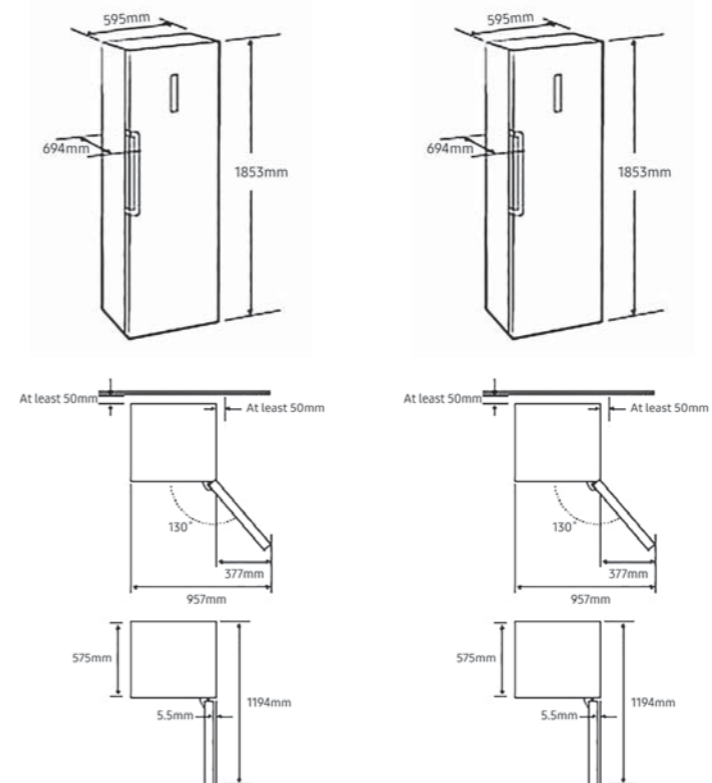

## Models/oven INSTALLATION GUIDE

NV73J9770RS, NV73J7740RS, BQ1VD6T131, NV75J7570RS, NV75J5540RS, NV75K5571RS, NV70K1340BS

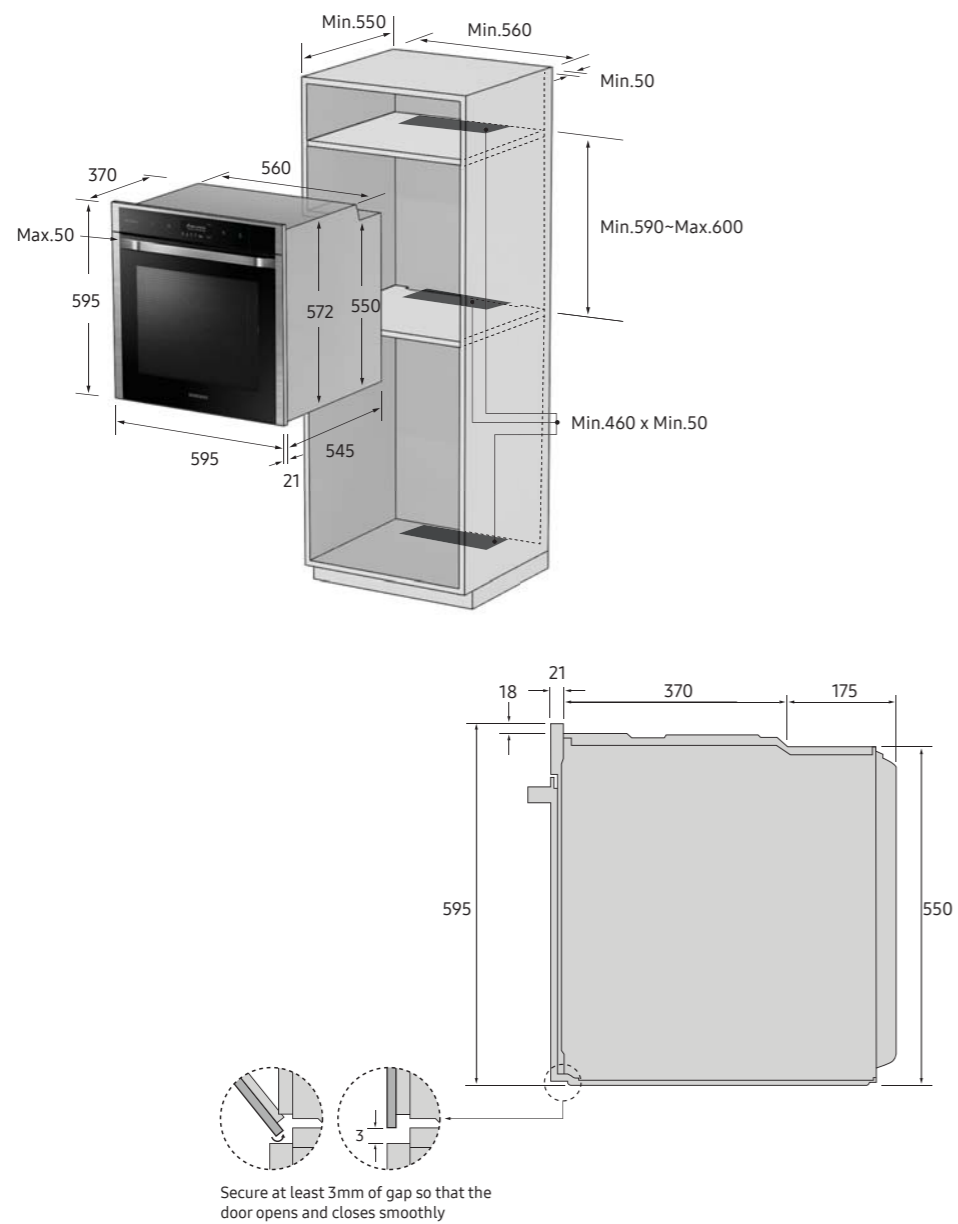

## Models/compact oven INSTALLATION GUIDE

NQ50J9530BS, NQ50J5530BS, NQ50K5130BS, NQ50K3130BM

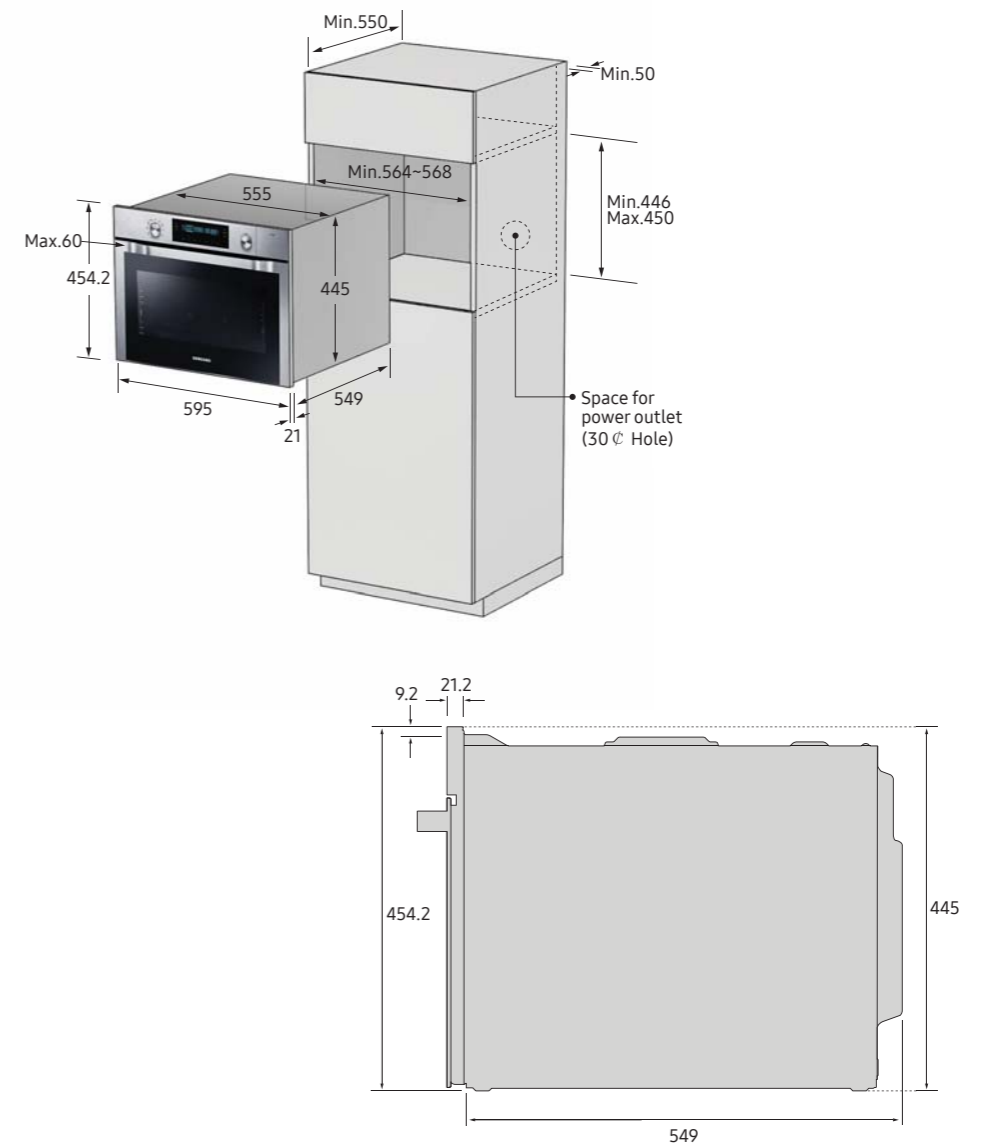

## Models/Warmer INSTALLATION GUIDE

NL20J7100WB

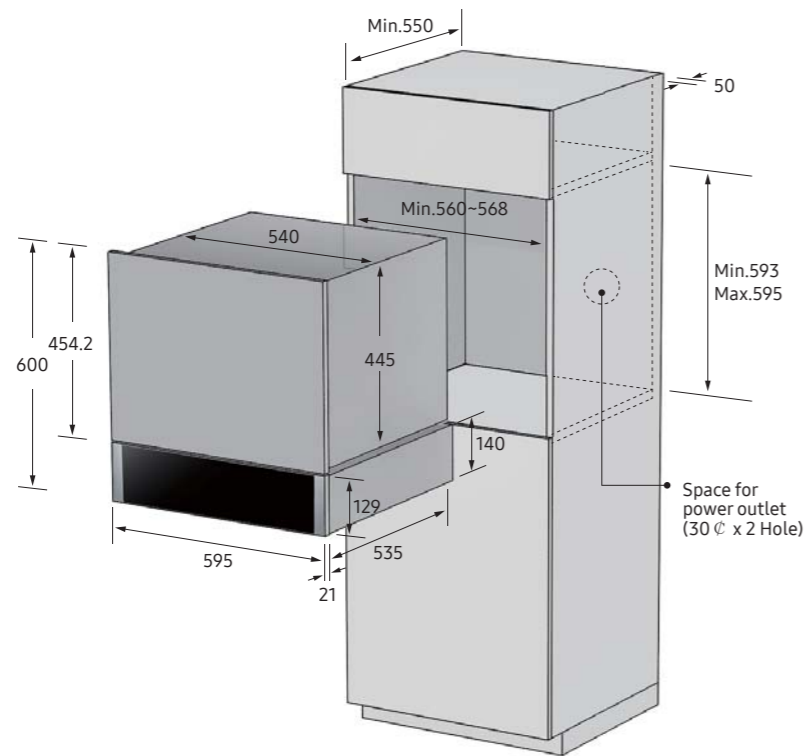

## Models/Microwave Oven INSTALLATION GUIDE

MS22M8074AT

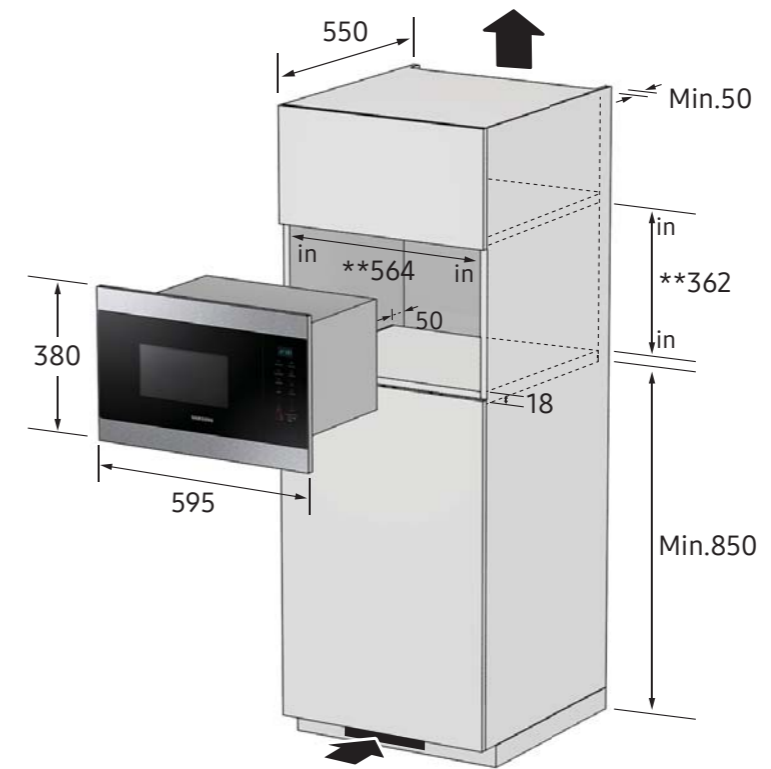

## Models/Induction Cooktop INSTALLATION GUIDE

NZ84J9770EK

NZ84F7NC6AB

NZ63J9770EK

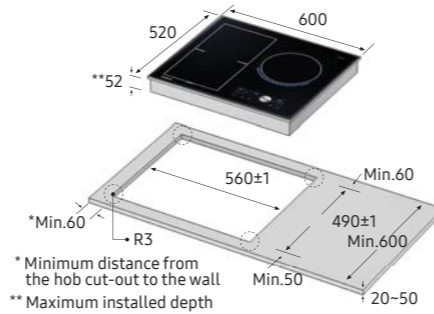
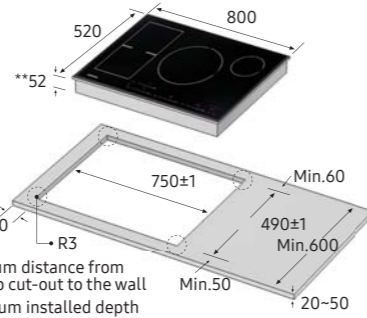
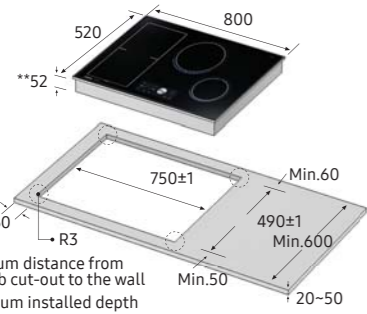

\* Minimum distance from the hob cut-out to the wall  
\*\* Maximum installed depth

\* Minimum distance from the hob cut-out to the wall  
\*\* Maximum installed depth

\* Minimum distance from the hob cut-out to the wall  
\*\* Maximum installed depth

## Models/Induction/Ceramic/Gas Cooktop INSTALLATION GUIDE

NZ64H37070K

C61R1AAMST

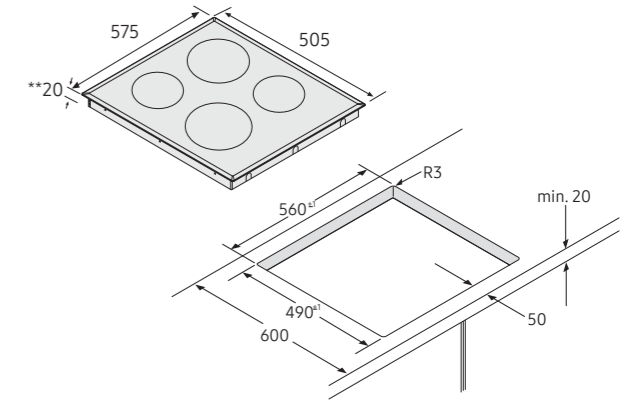
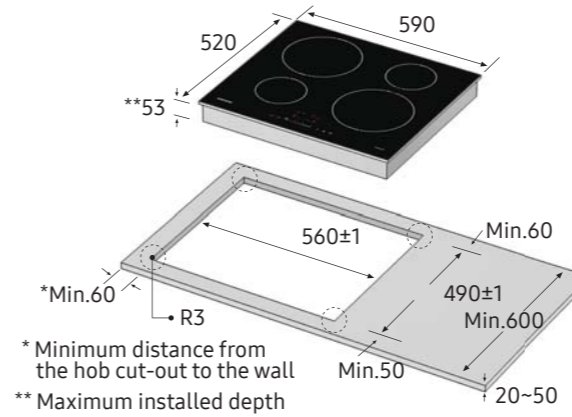

\* Minimum distance from the hob cut-out to the wall  
\*\* Maximum installed depth

NZ63K777BK

NZ64K7757BK

NA64H3000AK

NA64H3010AS

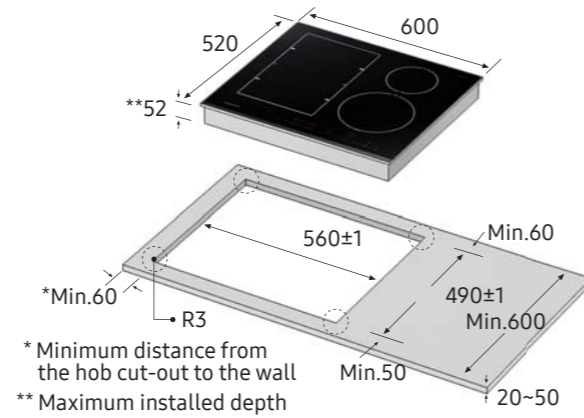
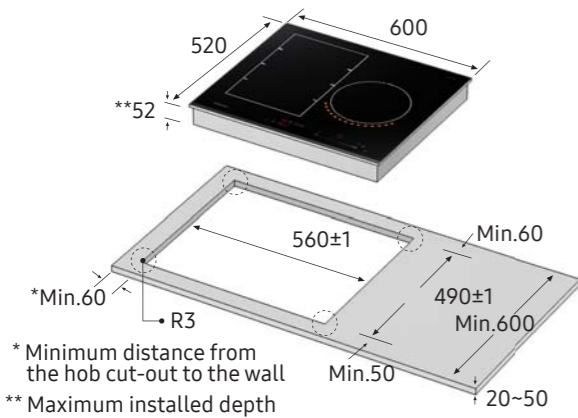

\* Minimum distance from the hob cut-out to the wall  
\*\* Maximum installed depth

\* Minimum distance from the hob cut-out to the wall  
\*\* Maximum installed depth

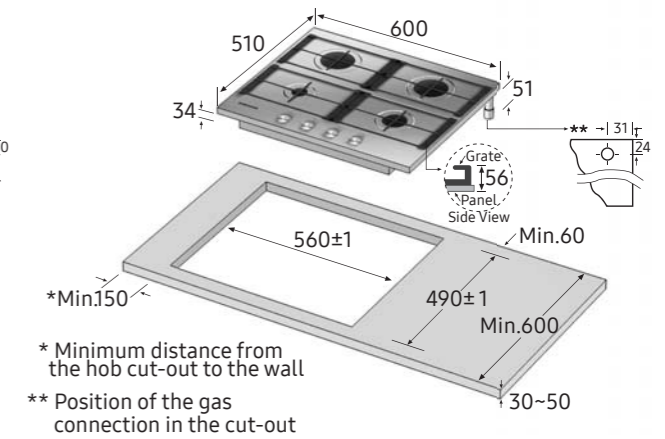
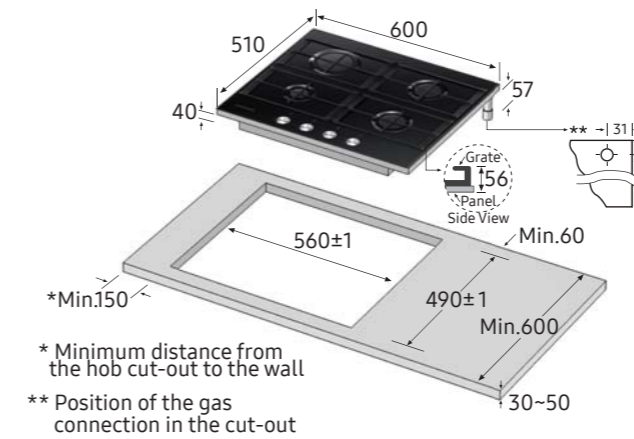

\* Minimum distance from the hob cut-out to the wall  
\*\* Position of the gas connection in the cut-out

\* Minimum distance from the hob cut-out to the wall  
\*\* Position of the gas connection in the cut-out

## Models/Gas Cooktop INSTALLATION GUIDE

NA75J3030AS

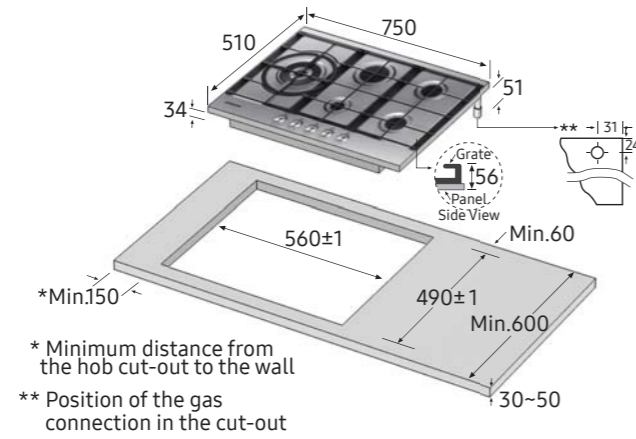

## Models/Hood INSTALLATION GUIDE

NK24M3050PS/60cm

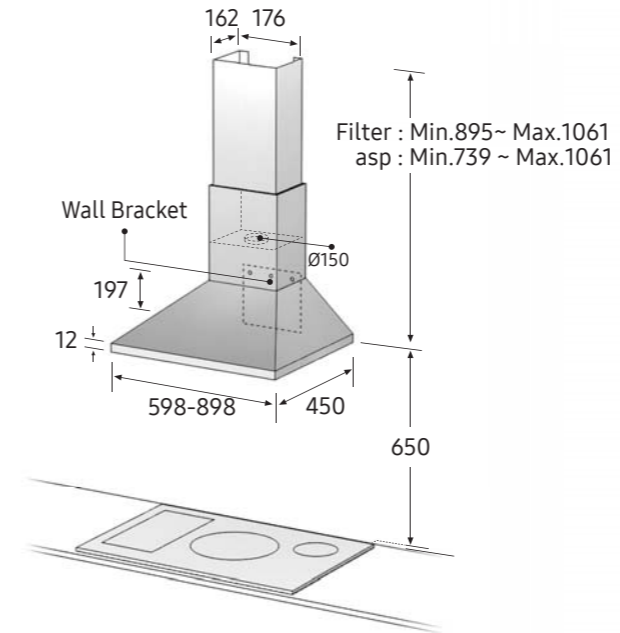

NK36M5070CS, NK24M5070CS/90cm, 60cm

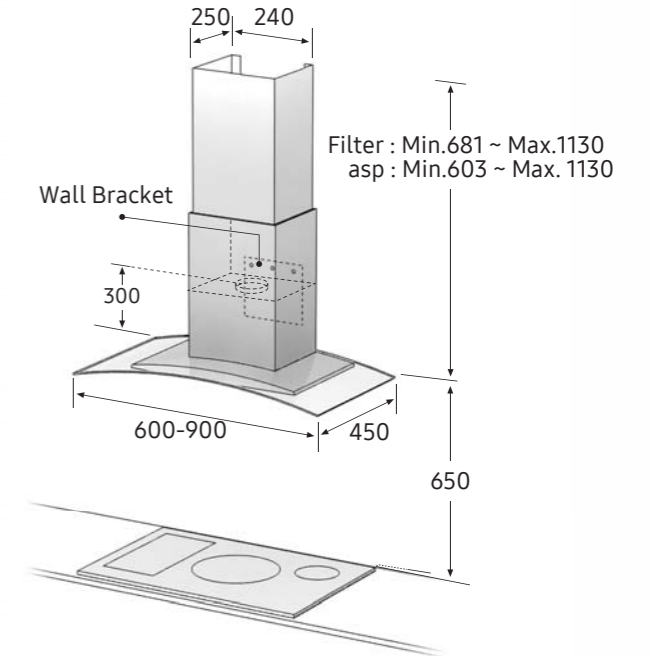

NK36M5070BM, NK24M5070BM/90cm, 60cm

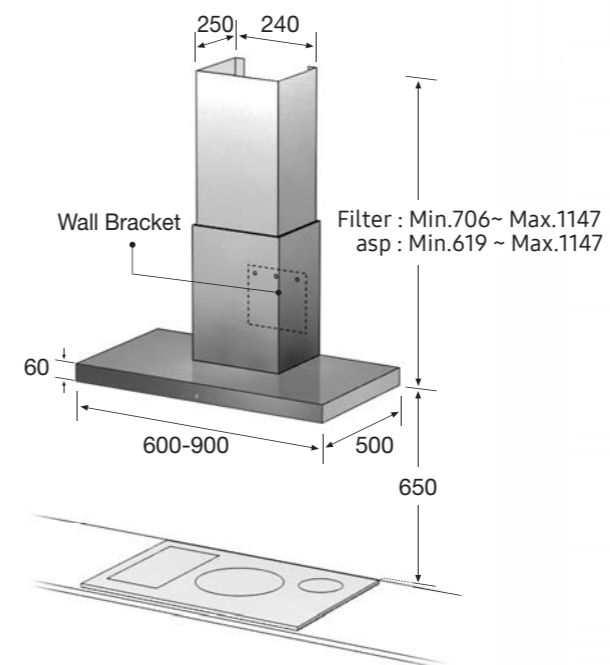

NK36M7070VS, NK24M7070VS/90cm, 60cm

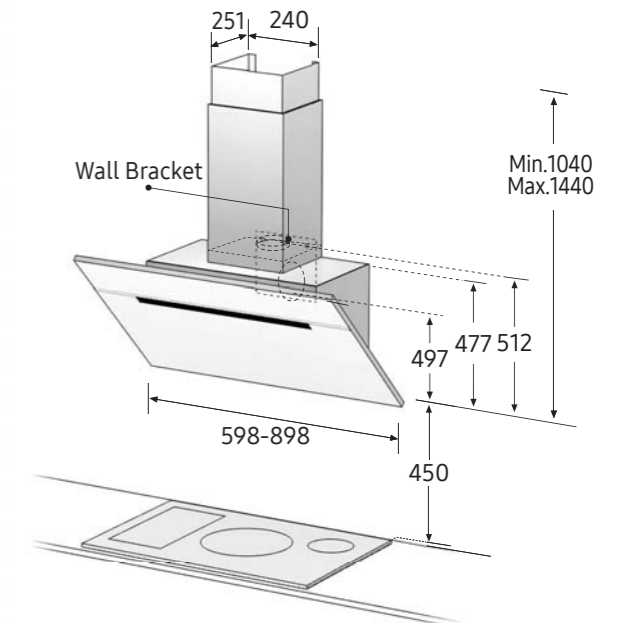

## Models/Fullsize Dishwasher (Fully Built-In) INSTALLATION GUIDE

DW50K4050BB

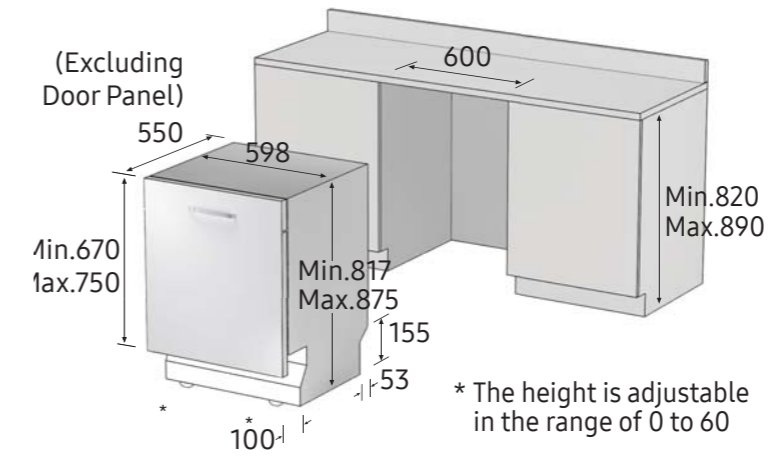
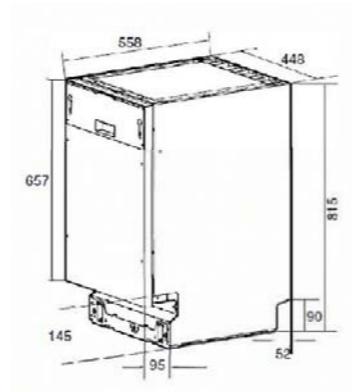
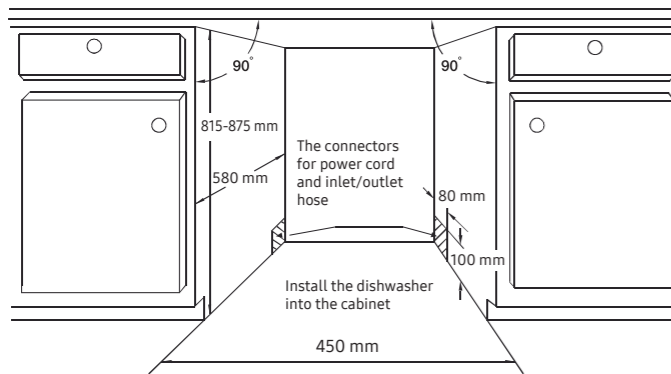

DW60M5040BB

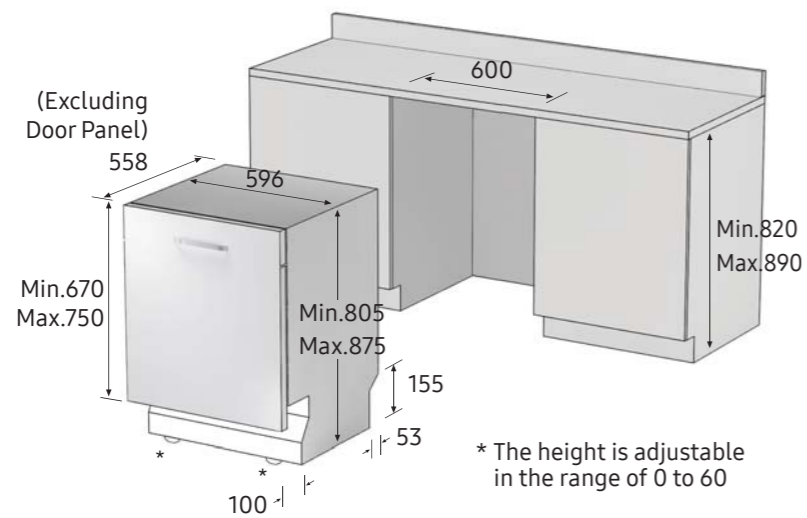

DW60J9970BB

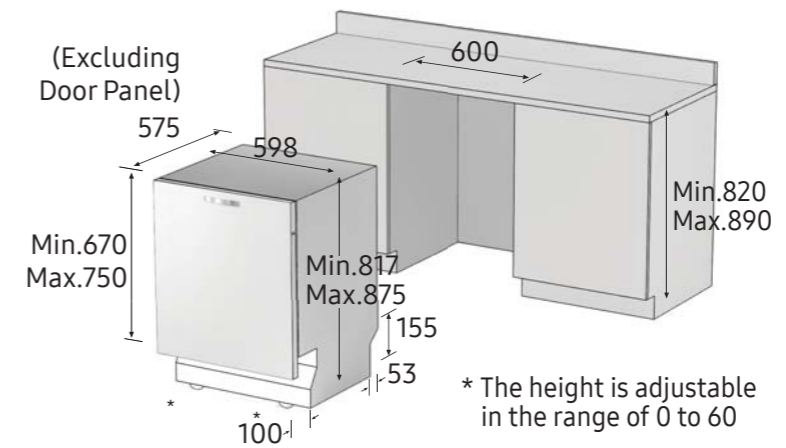



## Samsung Service

Samsung Customer Service is here to help you throughout the lifetime of your appliance. We provide everything from an expert repair service to helpful advice – giving you the level of service you expect from Samsung.

### Repair

When you buy a Samsung appliance you choose reliability and the best in quality. If, however, you require any help, Samsung Service can provide rapid and reliable assistance.

### Online Support

Many common issues can be easily solved with the correct advice. Our online FAQs give you helpful hints and tips to keep your appliance performing at its best.

<http://www.samsung.com/uk/support/category/homeappliance/>

### Contact us

Our customer service advisors are here to help.

Please visit: <http://www.samsung.com/uk/support/> for more details or call us on 0330 726 7864 (consumers), 0330 726 1001 (trade).

### Register your appliance and warranty

You should register all your appliances and warranties with Samsung to ensure we have full records in the event of any important product updates.

Please note selected models come with a free five year warranty on parts and labour which requires registration within 90 days of purchase, terms and conditions apply. [www.samsung.com/uk/fiveyearwarranty/](http://www.samsung.com/uk/fiveyearwarranty/)